

INVITATION

BEGINNER SHOW

April 11th & 12th 2015

PATTERNBOOK

★ First Show of WRAL Circuit 2015 ★

Location: Ecuries Hoffmann • 6, um Tunnel • L-3552 Dudelange

QUARTER
HORSE
ASSOCIATION
LUXEMBOURG



www.qhal.lu



STAGE DE PRÉPARATION, April 11, 2015

STARTS AT 12:00

The Stage de préparation will be an information clinic on:

- Showoutfit, (hat, shirts, boots, chaps,); Tack (bits, bridles,
- how to perform in different classes, mistakes, penalties, credits
- work on patterns

This stage will be held by Ricky Bordignon

General Rules and Informations:

ABSOLUTE BEGINNER SHOW April 12, 2015

First Show of WRAL Circuit 2015

CLASSES START AT 9:30

Org.: WRAL a. s. b. l., QHAL a. s. b. l., PHAL a s. b. l.,
7, op der Klopp, L-66954 Mompach

Location: Ecuries Hoffmann 6, um Tunnel, L-3552 Dudelange

Judge: Ricky Bordignon, Italy

Ringsteward: Karin Pauly, Emerange, Luxembourg

Show-office is open on Saturday April 11 from 12.00h to 18.00h and opens on April 12 at 8:30h.

LATE ENTRIES: LATE ENTRIES MAY BE ACCEPTED 1 hour before class

NACHNENNUNGEN: NACHNENNUNGEN MÖGLICH bis 1 Stunde vor Klasse

INSCRIPTIONS TARDIVES: INSCRIPTIONS TARDIVES ACCEPTÉE
jusqu'à 1 heure avant classe

WRAL Classes: - *AQHA rules are applied with following exceptions:*

- Youth -18 may also enter the Beginner, Amateur and Open Division. Youth may show two-handed on Snafflebit or Hackamore or onehanded on a Bit even senior horses.
- No stallions are allowed in Youth-Classes
- The Beginner division is reserved exclusively for competitors who have not won more than 3 times that class (Results of WRAL Beginner, WRAL-Amateur and WRAL-Open are added, (minimum of 3 entries),
- Beginner may show twohanded on Snafflebit or Hackamore or onehanded on a Bit even senior horses.
- In all WRAL-classes the horse does not need to be owned by the competitor.
- Trail in Hand APHA rules will be applied ·Horse&Dog-Trail EWU rules will be applied (Western- or English-Dress)

FLSE classes:

(just for FLSE licensed riders): AQHA rules are applied with the following exception:

- In FLSE-Youth and FLSE-Open classes the horse does not need to be owned by the competitor.
- The competitor needs to own an FLSE-Western or FLSE-Competition license,
- The horse does not need be registered.

Horses and Dogs

must be vaccinated and covered by a liability insurance and be free of disease on the showday. Neither the show-management nor the owner of the arena accept any responsibility for accident, loss or damage to persons, horses, dogs and material.

Rights on Photos, Videos etc:·

With the signature, each participant agrees that photos and or videos taken on the show-ground can be published.

**Stage de préparation on SATURDAY April 11, 2015
starts at 12:00 (no office charge required)**

1			Showmanship and Trail in Hand	
2			Trail	
3			Ranch Pleasure	
4			Horsemanship, Pleasure	
5			Reining	

**Absolute Beginner Show on SUNDAY April 12, 2015
First Show in WRAL Circuit 2015
!! CLASSES START AT 9:30am !!**

6	WRAL	1202	SHOWMANSHIP AT HALTER	BEGINNER
7	WRAL	1201	SHOWMANSHIP AT HALTER	AMATEUR
	Break 15 minutes			
8	WRAL	3822	TRAIL IN HAND (all ages)	BEGINNER
	Break 10 minutes			
9	WRAL	3823	Horse&Dog Trail	BEGINNER
10	WRAL	3812	TRAIL WALK-TROT	BEGINNER
11	WRAL	3802	TRAIL	BEGINNER
12	WRAL	3801	TRAIL	AMATEUR
13	FLSE/WRAL	380	TRAIL	OPEN
14	FLSE/WRAL	3804	TRAIL	YOUTH
15	WRAL	2405	HORSEMANSHIP WALK-TROT	BEGINNER
16	WRAL	4214	WESTERN PLEASURE WALK-TROT	YOUTH
17	WRAL	4302	RANCH PLEASURE	BEGINNER
18	WRAL	4301	RANCH PLEASURE	AMATEUR
	Lunch Break			
19	WRAL	111	LEAD-LINE	YOUTH
20	WRAL	4205	WESTERN PLEASURE WALK-TROT	BEGINNER
21	WRAL	2402	WESTERN HORSEMANSHIP	BEGINNER
22	WRAL	2401	WESTERN HORSEMANSHIP	AMATEUR
23	WRAL	4202	WESTERN PLEASURE	BEGINNER
24	WRAL	4201	WESTERN PLEASURE	AMATEUR
25	FLSE/WRAL	420	WESTERN PLEASURE AA.	OPEN
26	FLSE/WRAL	4204	WESTERN PLEASURE	YOUTH
	Break 10 minutes			
27	WRAL	3402	REINING AA.	BEGINNER
28	WRAL	3401	REINING AA.	AMATEUR
29	FLSE/WRAL	3404	REINING	YOUTH
30	FLSE/WRAL	340	REINING AA.	OPEN

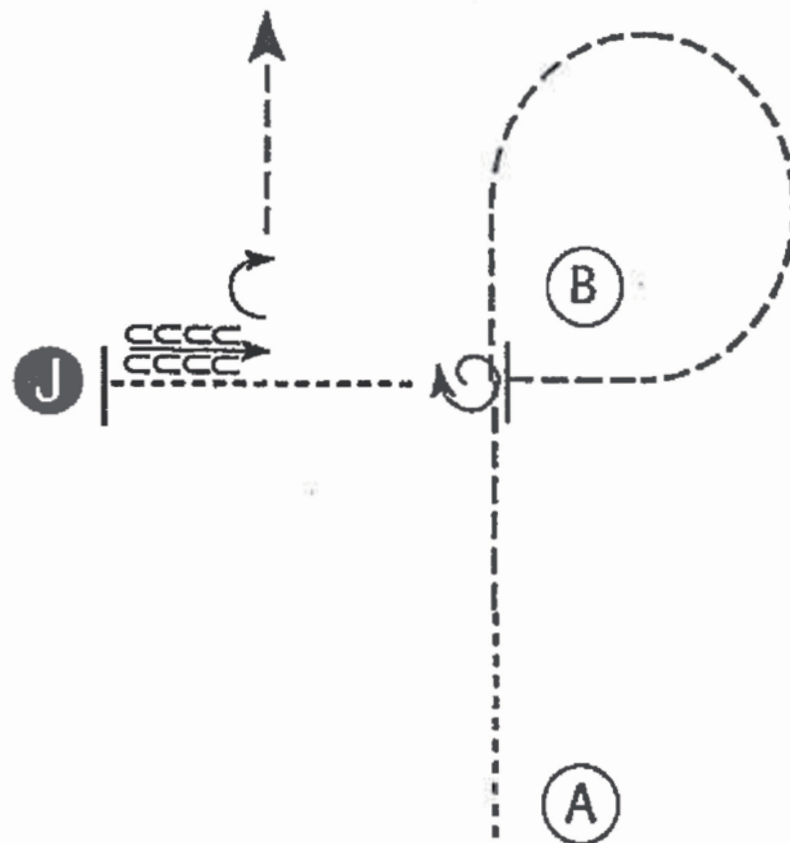

Be ready at A.

1. Walk halfway to B.
2. Trot to and around B as shown.
3. Stop when just past B. Perform a 360 degree turn.
4. Walk to judge and set up for inspection.
5. When dismissed, back one horse length.
6. Perform a 90 degree turn and trot away.

Follow the instructions of your ring steward.

Walk	-----
Trot	- - - - -
Back	← CCCC
Marker	ⓑ
Judge	ⓐ

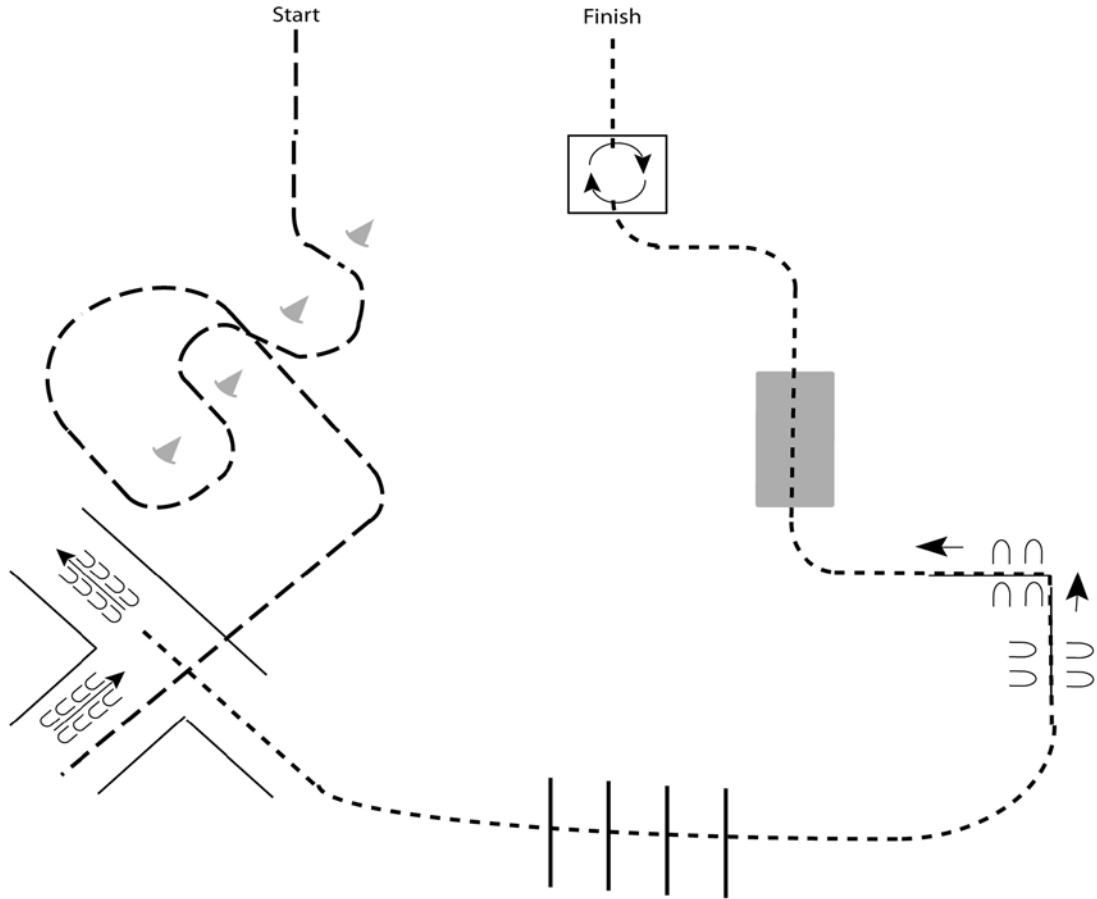

1. Trot through cones
2. Continue to trot into chute
3. Back the L
4. Walk over poles to sidepass
5. Sidepass left over poles
6. Walk over bridge and into box
7. Perform a 360 degree turn to the right, walk out of box and to finish

Walk	-----
Jog	-----
Extended Jog	-----
Lope	-----
Leg Yield	
Lead Change	↘↙
Back	←←←←←
Marker	(B)
Sidepass	←-----→

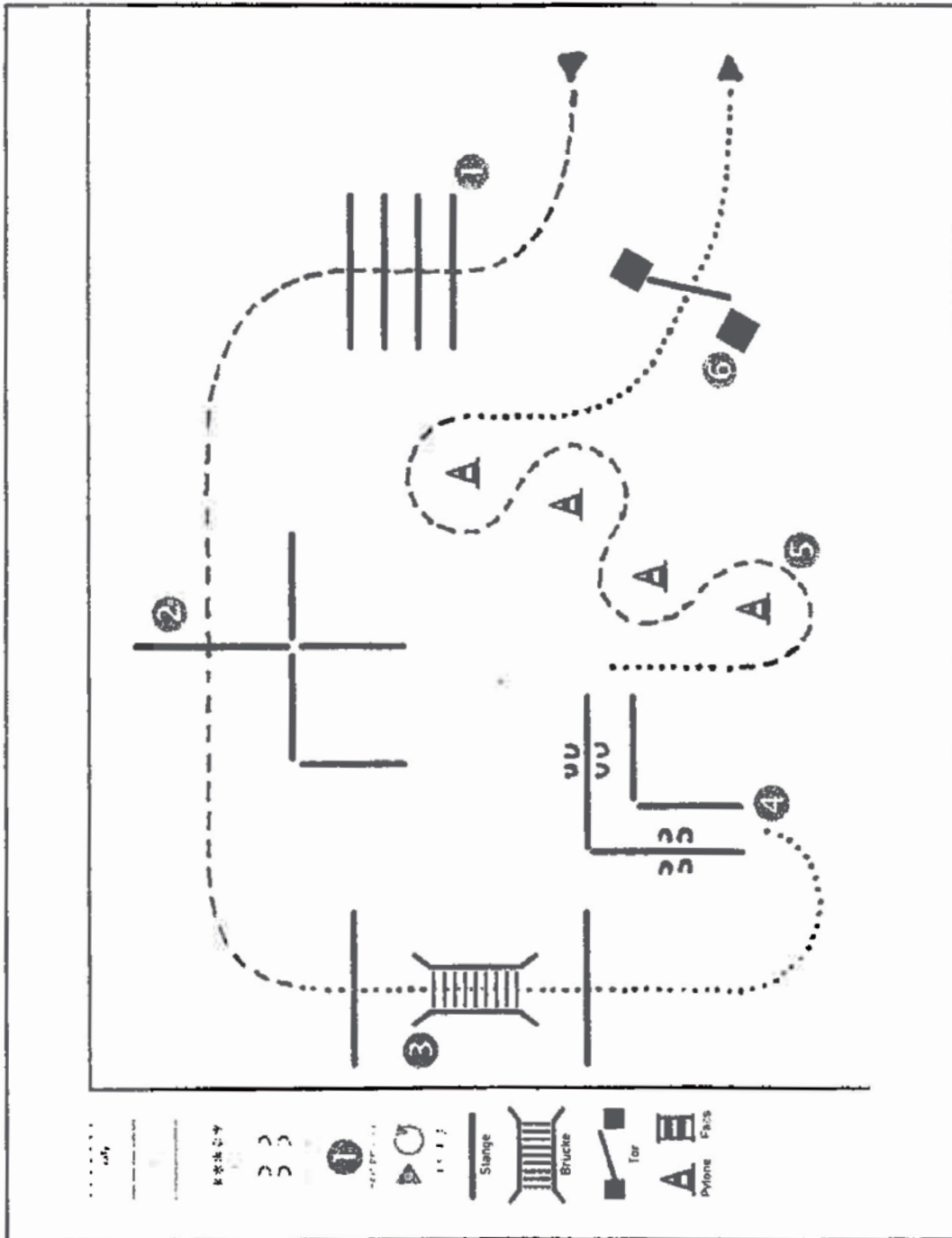

- beim Eintritt in die Arena im Schritt ist der Hund angeleint und läuft bei Fuß (Seite spielt keine Rolle) der Hund wird an der Pylone abgeleint
- zu 1.) im Trab über die Stangen, der Hund geht bei Fuß, Trab zu 2.)
- zu 2.) im Trab über die Stange, der Hund geht bei Fuß, Schritt zu 3.)
- zu 3.) im Schritt über die Brücke, der Hund wird geschickt oder hinterhergerufen, Schritt zu 4.)
- zu 4.) der Hund wird abgelegt, der Reiter geht seitwärts über die Stangen, der Hund wird abgerufen, Schritt zu 5.)
- zu 5.) im Trab um die Pylonen, der Hund geht bei Fuß, Schritt zu 6.)
- 6.) der Reiter reitet im Schritt zum Tor und reitet hindurch, der Hund wird abgerufen
- Schritt zum Ausgang, der Hund wird an der Pylone angeleint
- Ende der Prüfung, im Schritt die Arena verlassen

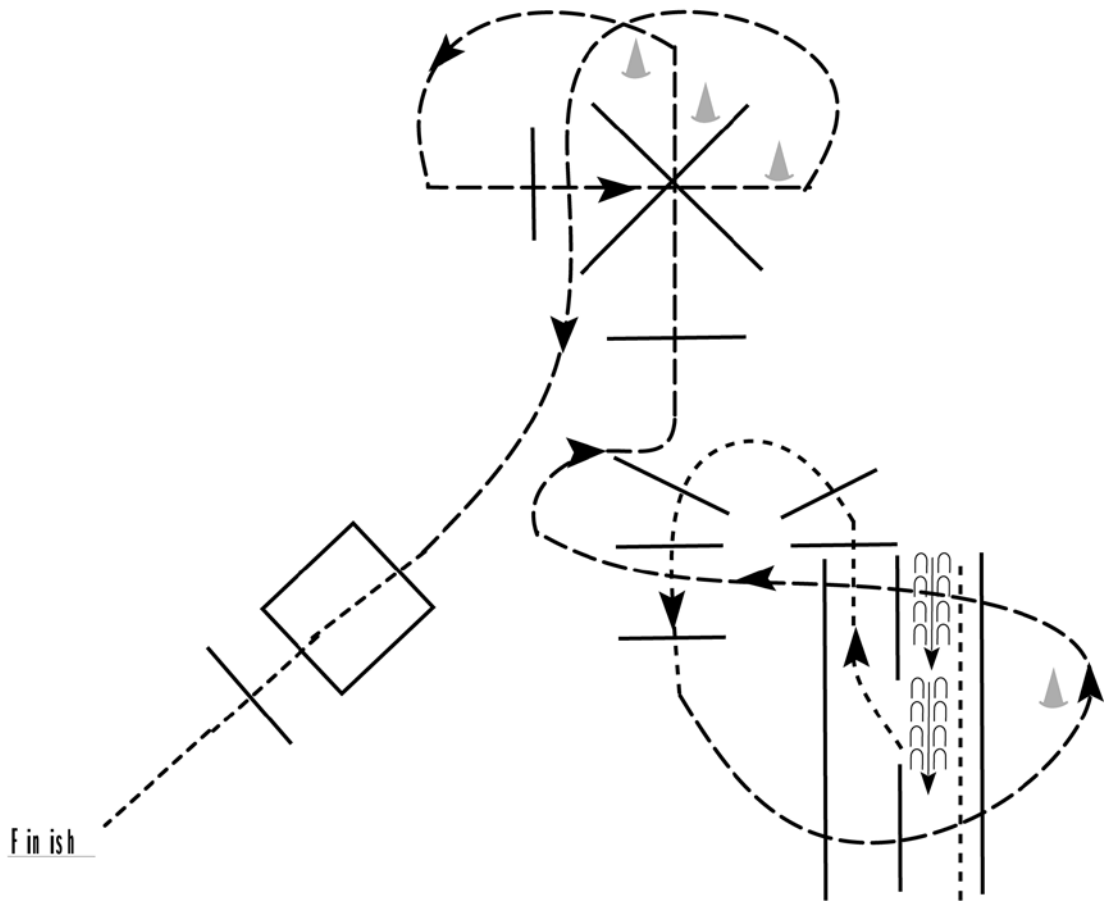

1. Walk into chute and back straight.
2. Walk out and over 5 poles.
3. Jog thru chute.
4. Jog over pole and X.
5. Continue to jog over pole and X.
6. Jog to box as shown.
7. Walk thru box and pole to finish.

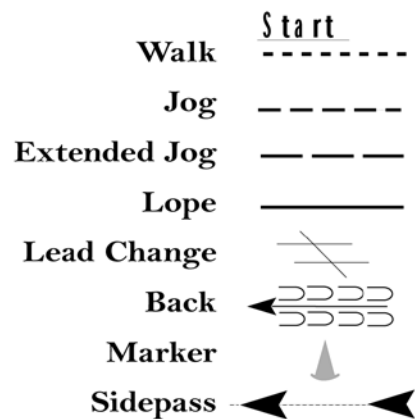

[T/WT-35]

www.HorseShowPatterns.com

www.HorseShowPatterns.com

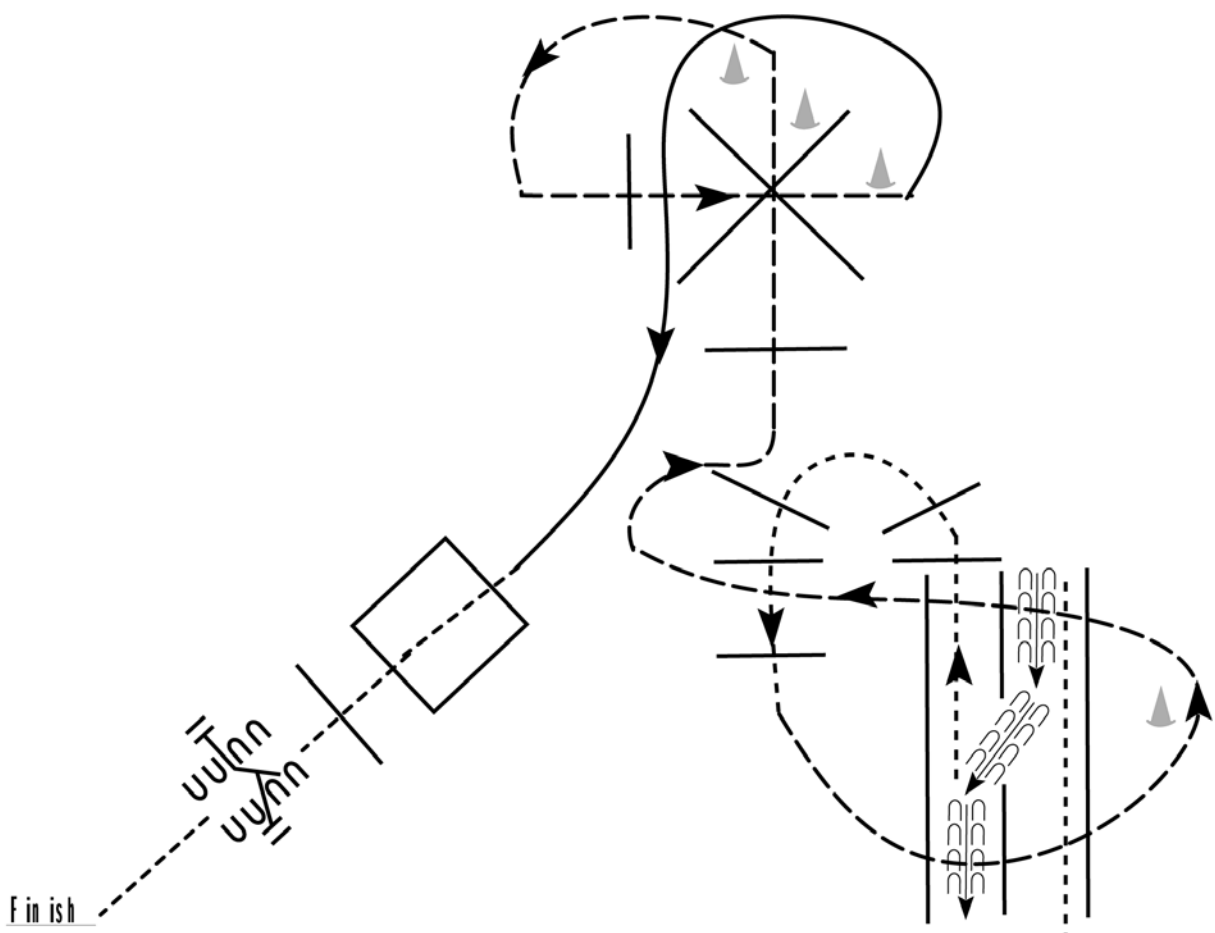

1. Walk into chute and back thru.
2. Walk out and over 5 poles.
3. Jog thru chute.
4. Jog over pole and X.
5. Continue to jog over pole and X.
6. Lope on the left lead to box as shown.
7. Walk thru box to gate.
8. Work gate with left hand.
9. Walk to finish.

Walk	Start	-----
Jog		-----
Extended Jog		-----
Lope		—————
Lead Change		—/—
Back		← C C C C C
Marker		▲
Sidepass		←-----→

12	WRAL	3801	TRAIL	AMATEUR
14	WRAL/FLSE	3804	TRAIL	YOUTH

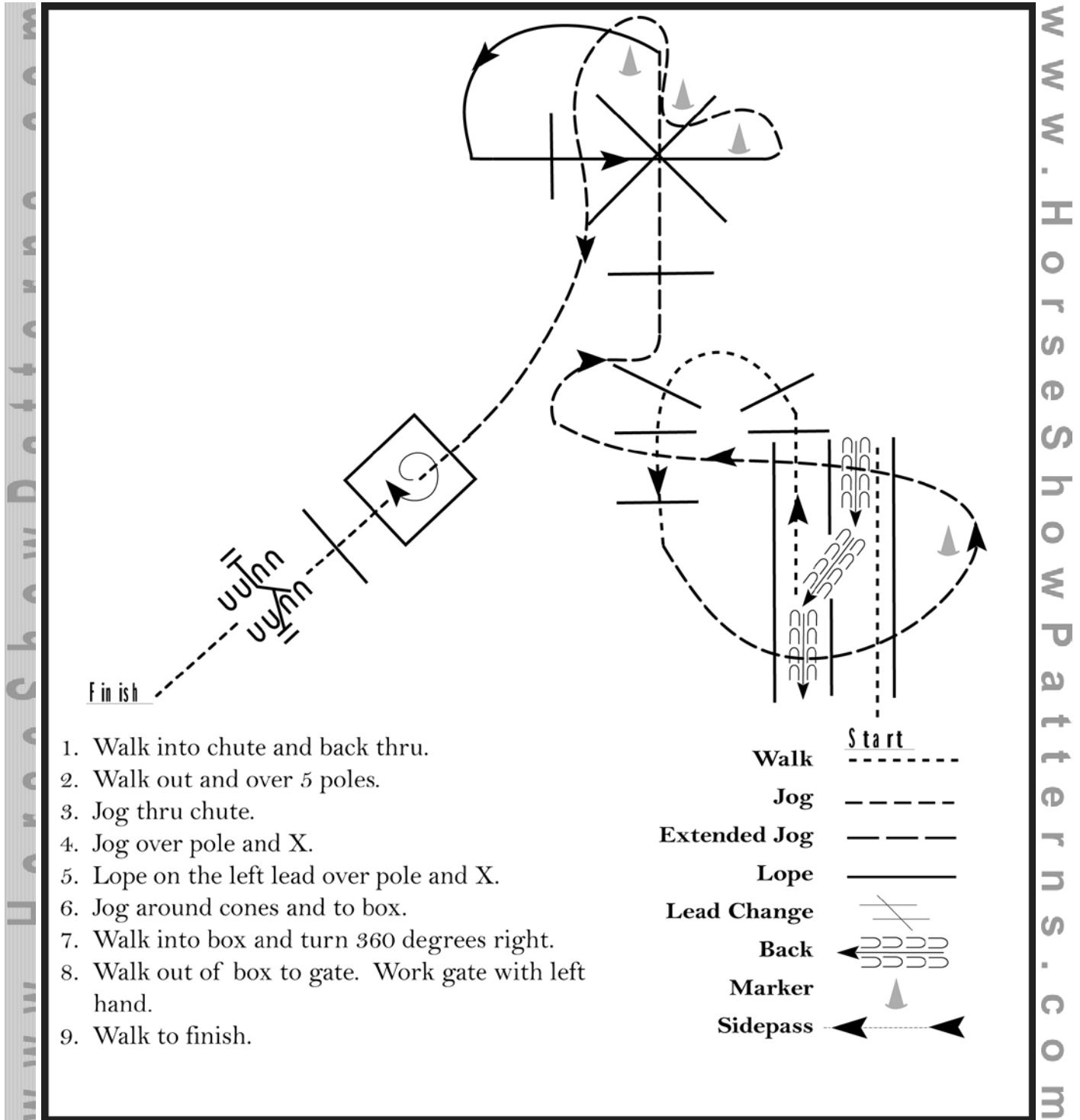

1. Walk into chute and back thru.
2. Walk out and over 5 poles.
3. Jog thru chute.
4. Jog over pole and X.
5. Lope on the left lead over pole and X.
6. Jog around cones and to box.
7. Walk into box and turn 360 degrees right.
8. Walk out of box to gate. Work gate with left hand.
9. Walk to finish.

Start

Walk -----

Jog (dotted)

Extended Jog - - - - -

Lope _____

Lead Change / \

Back ← ← ← ← ←

Marker ▲

Sidepass ← ← ← ← ←

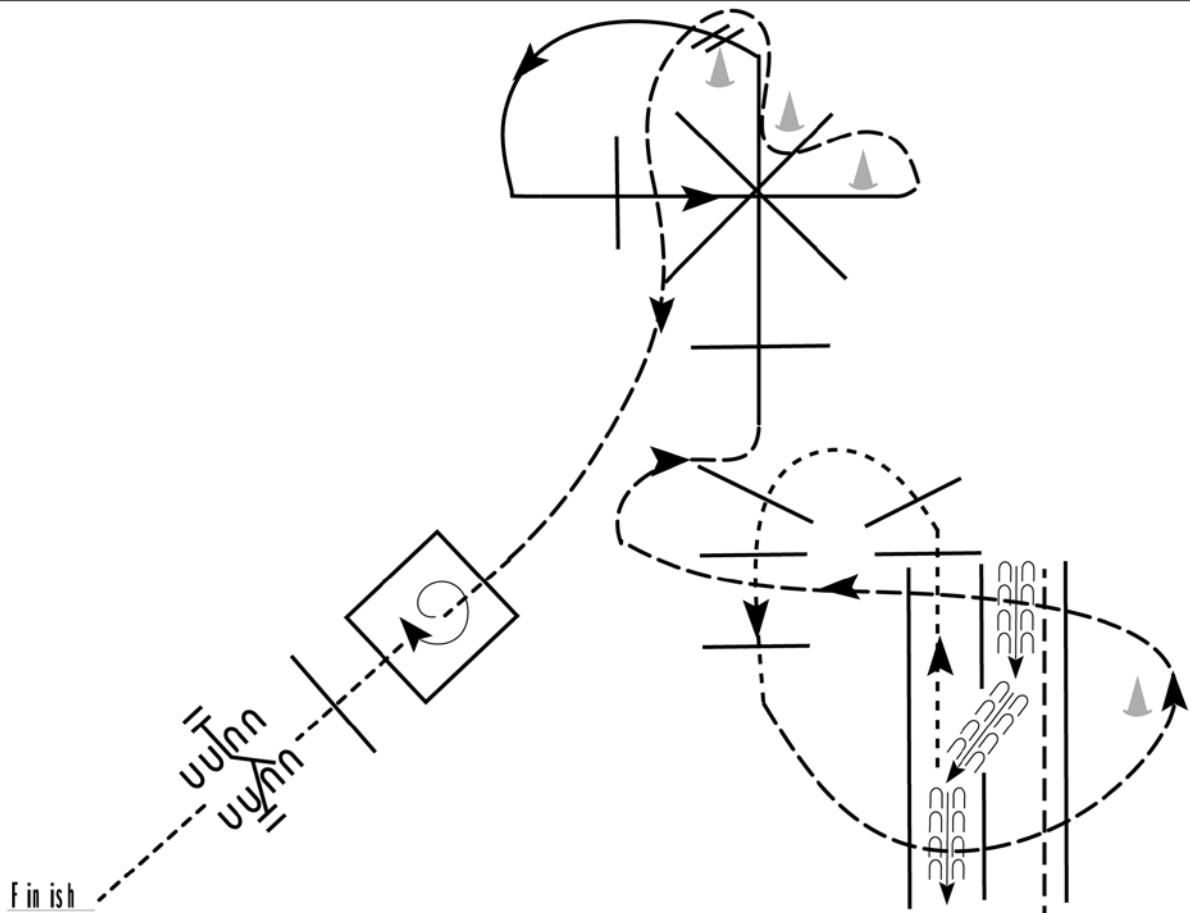

1. Jog into chute and back thru.
2. Walk out and over 5 poles.
3. Jog thru chute.
4. Lope over pole and X on right lead.
5. Change leads and lope on the left lead over pole and X.
6. Jog around cones and to box.
7. Walk into box and turn 360 degrees right.
8. Walk out of box to gate. Work gate with left hand.
9. Walk to finish.

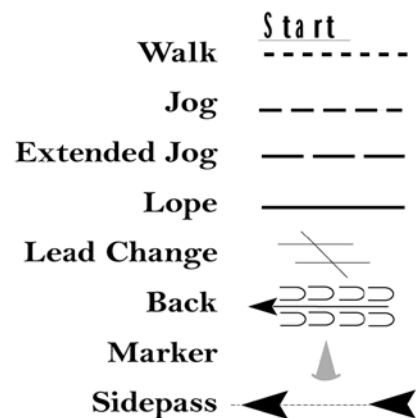

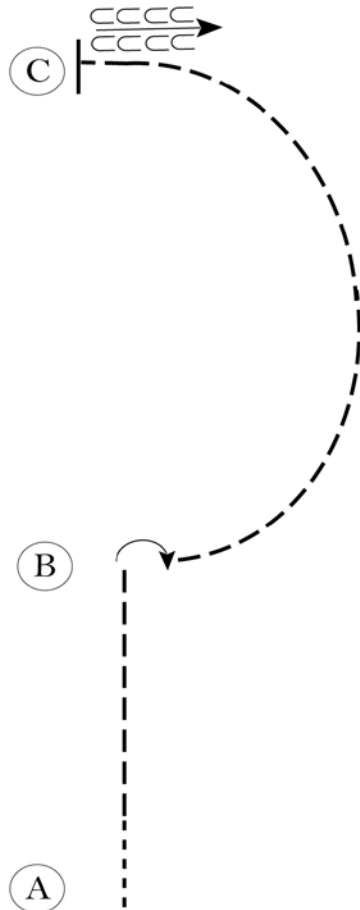

Be ready at A.

1. Walk approximately 2 horse lengths from A.
2. Jog to B.
3. Turn 1/4 turn to the right.
4. Jog in a half circle to C.
5. Stop at C and back approximately one horse length.

Follow the instructions of your ring steward.

Walk	-----
Jog	-----
Extended Jog	-----
Lope	-----
Leg Yield	
Lead Change	— / —
Back	← C C C C C C C C C C
Marker	(B)
Sidepass	←-----→

17	WRAL	4302	RANCH PLEASURE	BEGINNER
18	WRAL	4301	RANCH PLEASURE	AMATEUR

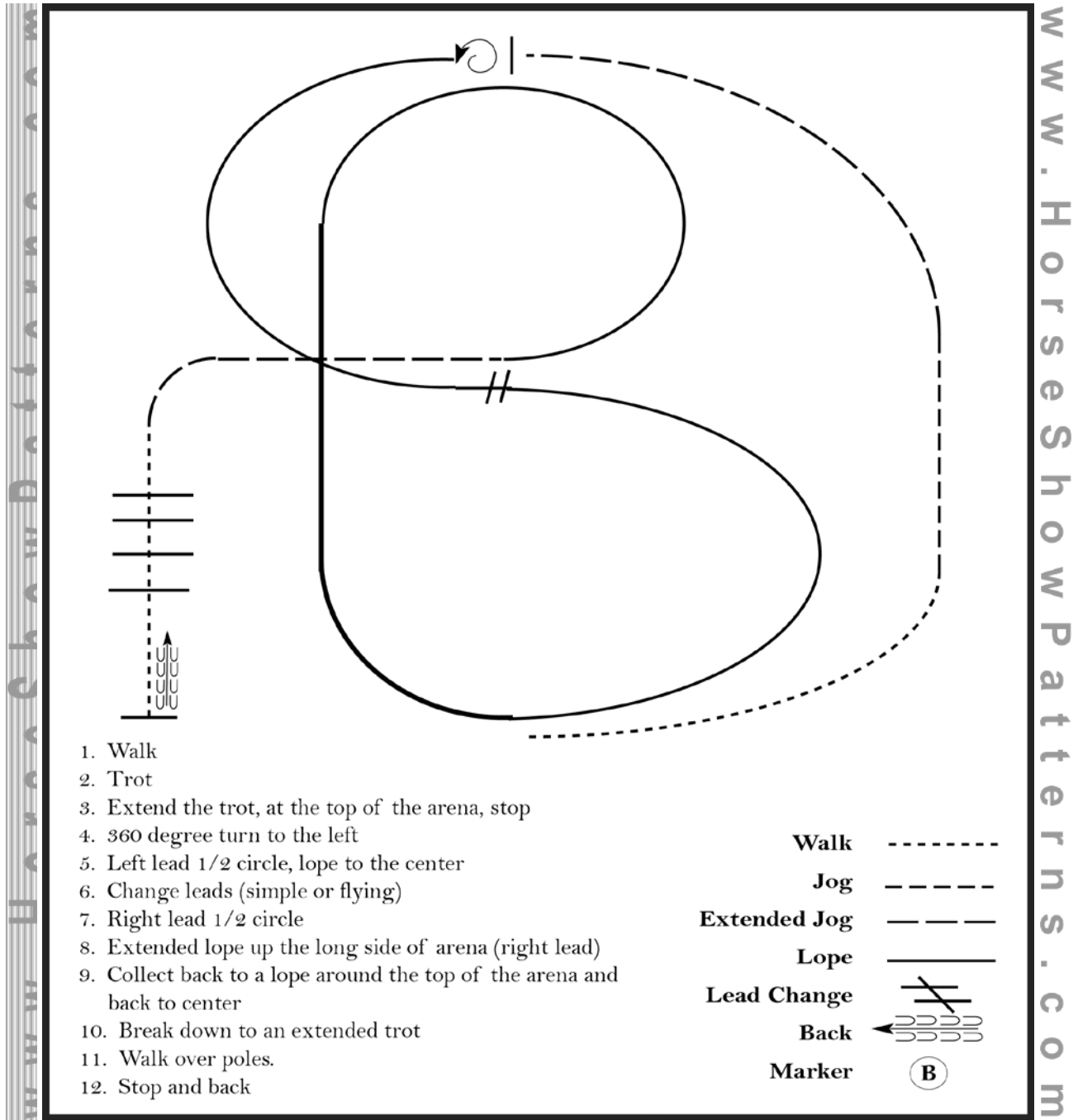

[RP/1]

www.HorseShowPatterns.com

www.HorseShowPatterns.com

Be ready at A.

1. Jog from A to B.
2. Stop at B and turn 90 degrees to the right.
3. Lope on the left lead around B as shown.
4. Break to the jog at B and jog to A.
5. Stop at A and back approximately one horse length.
6. Walk forward and follow the instructions of your ring steward..

Walk	-----
Jog	- - - - -
Extended Jog	- - - - -
Lope	—————
Leg Yield	
Lead Change	— / —
Back	← — — — — — — — — —
Marker	⊙ B
Sidepass	← — — — — →

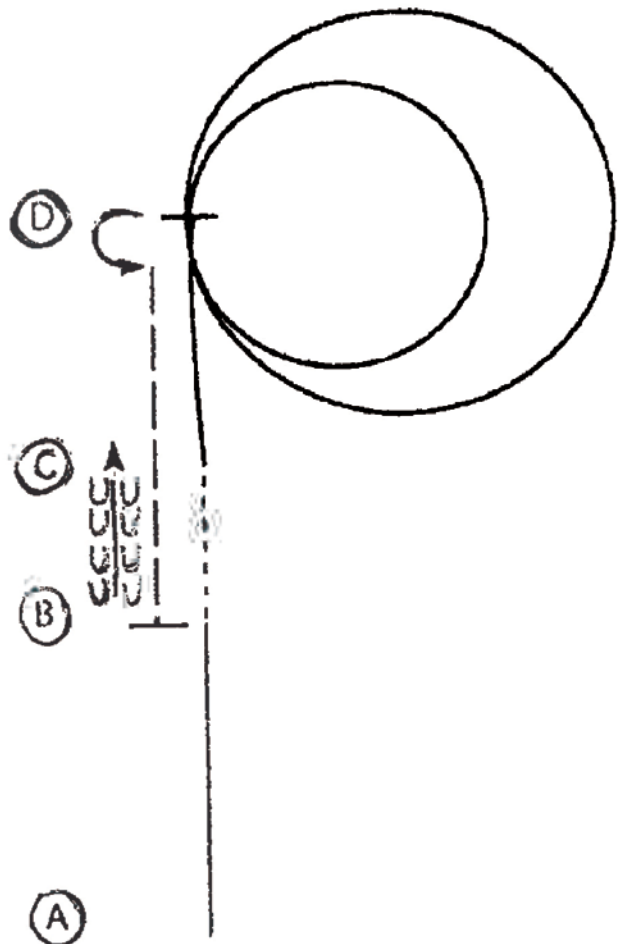

Be ready at A.

1. Lope on the left lead to B.
2. Walk B to C.
3. Lope on the right lead to D.
4. Lope a large fast circle to the right.
5. Lope a small slow circle to the right.
6. Stop at D and perform a 180 degree spin to the left.
7. Extend the jog to B.
8. Stop at B and back to C.

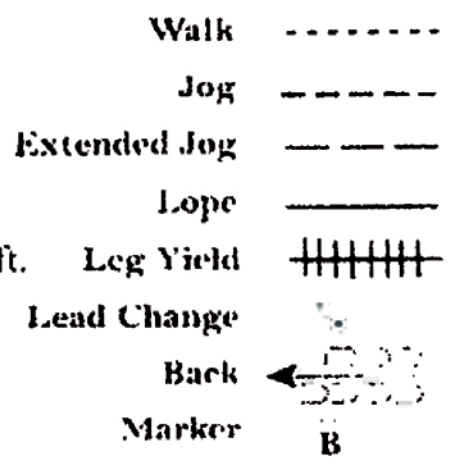

Follow the instructions of your ring steward.

REINING PATTERN 13

Approved only for Level I (Novice) Youth and Amateur, Youth 13 & Under and
EWD Independent Walk, Trot, Lope

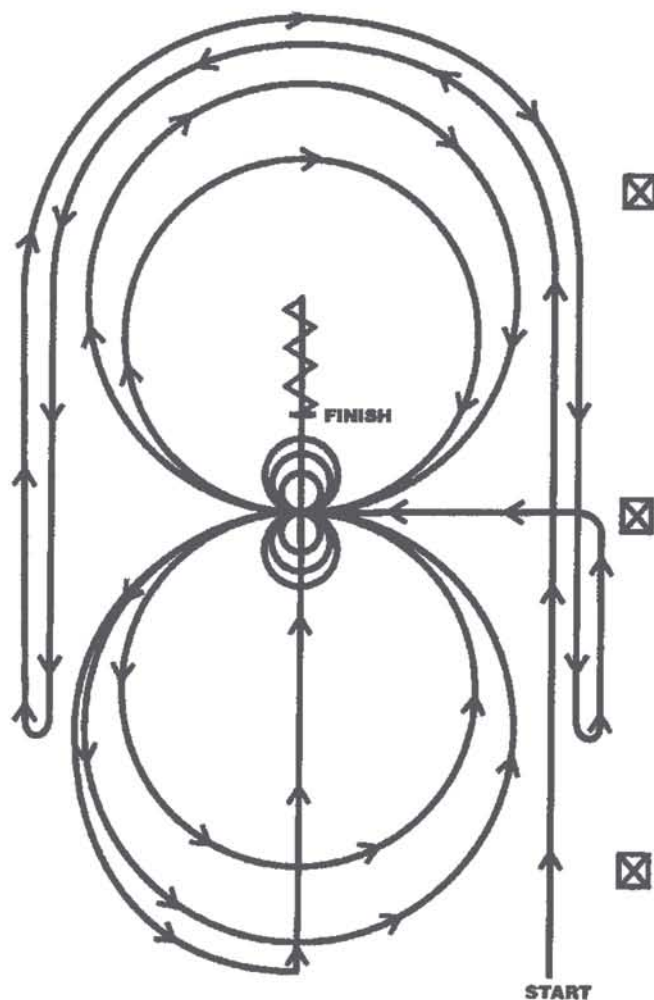

1. Run around the end of the arena, run down the left side past center marker, right rollback
2. Run around end of arena, run down right side past center marker, left rollback
3. Left circles, one large fast and one small slow, stop at center
4. 3 spins left, hesitate
5. Right circles, one large fast and one small slow, stop at center
6. 3 spins right, hesitate
7. Begin large fast circle to left at the top of the circle, run down the center of arena past center marker, stop.
8. Back up at least 10 feet, hesitate.

Hesitate to show completion of pattern.

28	WRAL	3401	REINING AA.	AMATEUR
29	WRAL/FLSE	3404	REINING	YOUTH

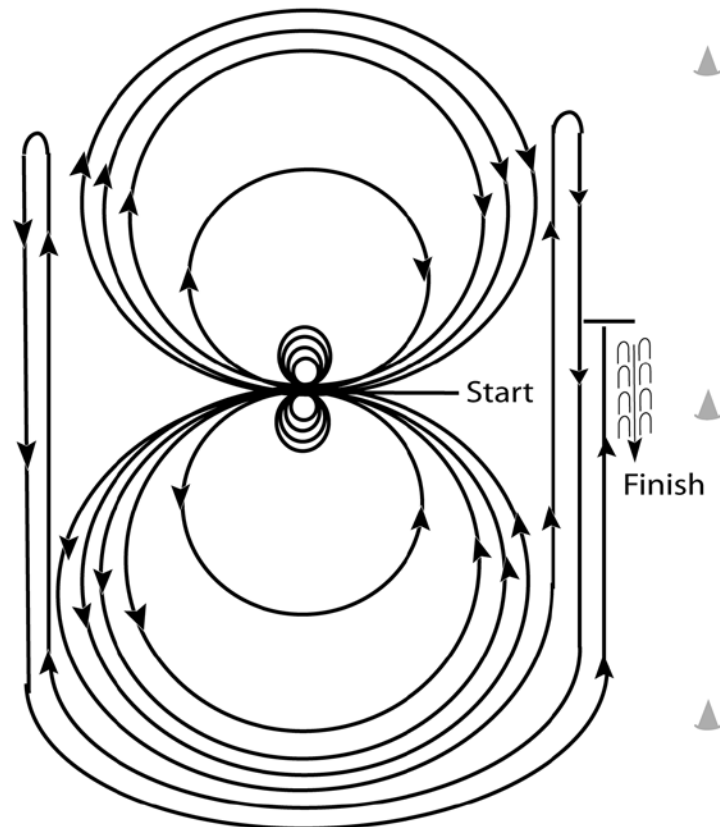

Horses must walk or stop prior to starting pattern. Beginning at the center of the arena facing the left wall or fence.

1. Beginning on the left lead, complete three circles to the left: the first two circles large and fast; the third circle small and slow. Stop at the center of the arena.
 2. Complete four spins to the left. Hesitate.
 3. Beginning on the right lead, complete three circles to the right: the first two circles large and fast; the third circle small and slow. Stop at the center of the arena.
 4. Complete four spins to the right. Hesitate.
 5. Beginning on the left lead, run a large fast circle to the left, change leads at the center of the arena, run a large fast circle to the right, and change leads at the center of the arena.
 6. Continue around previous circle to the left but do not close this circle. Run up the right side of the arena past the center marker and do a right rollback at least twenty feet (6.09m) from the wall or fence – no hesitation.
 7. Continue around previous circle but do not close this circle. Run up the left side of the arena past the center marker and do a left rollback at least twenty feet (6.09m) from the wall or fence – no hesitation.
 8. Continue back around previous circle but do not close this circle. Run up the right side of the arena past the center marker and do a sliding stop at least twenty feet (6.09m) from the wall or fence. Back up at least ten feet (3m). Hesitate to demonstrate completion of the pattern.
- Rider may drop bridle to the designated judge.

[R/AQHAP-5]

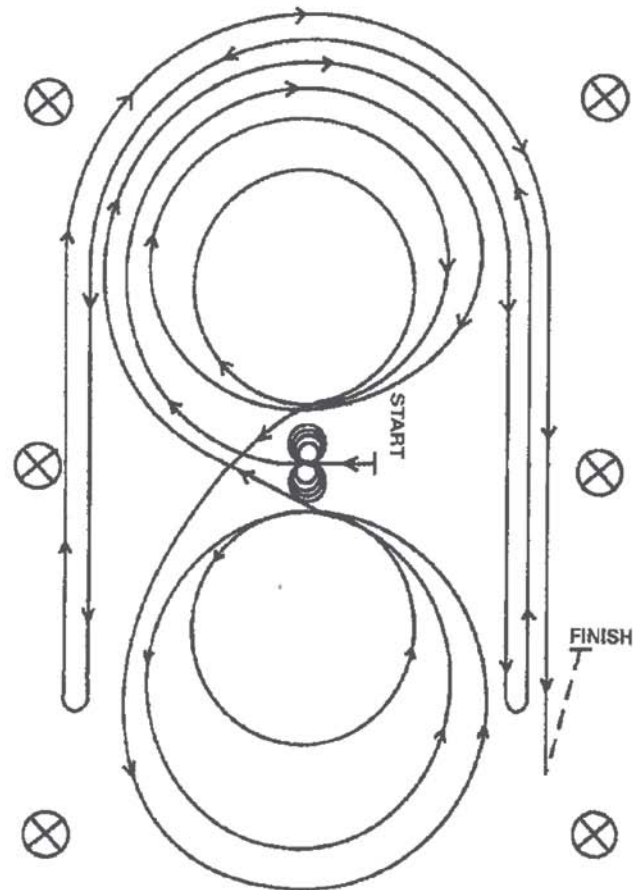
REINING PATTERN 8

Horse must walk or stop prior to starting pattern.

Beginning at the center of the arena facing the left wall or fence.

1. Complete four spins to the left.
2. Complete four spins to the right. Hesitate.
3. Beginning on the right lead, complete three circles to the right: the first circle large and fast; the second circle small and slow; the third circle large and fast. Change leads at the center of the arena.
4. Complete three circles to the left: the first circle large and fast; the second circle small and slow; the third circle large and fast. Change leads at the center of the arena.
5. Begin a large fast circle to the right but do not close this circle. Run straight down the right side of the arena past the center marker and do a left rollback at least 20 feet (6 meters) from the wall or fence - no hesitation.
6. Continue back around the previous circle but do not close this circle. Run down the left side of the arena past the center marker and do a right rollback at least 20 feet (6 meters) from the wall or fence - no hesitation.
7. Continue back around the previous circle but do not close this circle. Run down the right side of the arena past the center marker and do a sliding stop at least 20 feet (6 meters) from the wall or fence. Back up at least 10 feet. Hesitate to demonstrate completion of the pattern.

Rider may drop bridle to the designated judge.

★ We wish you ★



QUARTER
HORSE
ASSOCIATION
LUXEMBOURG



www.qhal.lu