

WESTERN HORSE SHOW

Semptember 20th & 21th 2014 Noertzange

PATTERNBOOK



CEEN Noertzange
1, rue de l'école
L-3395 Noertzange

www.ghal.lu

QUARTER
HORSE
ASSOCIATION
LUXEMBOURG



special thanks to our sponsors:

VIESSMANN
système d'énergie

Baumert

BGL BNP PARIBAS

PEINTURE - DECOR
BERTHAUT & BIVER

BRESCAGLIA
SERRAVALLO

carrelages louis scuri

Garage Baby Cruciani

COLLE

LAWAZZA

M
MIPKLES

Landat.lu

FIFEL
PferdeZAHNFEH

PROUD

Reifen Kaeren

TEAM WMB

3
Key Marke

phillipps
Reifen vom Steinbrücker

Inter Central Print

Jama

UNIVERS CLODS & PONS
SACC - BERHALLER FÖRDERER

Trierweiler

Dawen-Weibler
Wenig Gebraucht - Qualitätsschnitt

eQuaktiv

D.E. Oberholzer
Western Cover

GO

Rénovation de votre salle de bains de A-Z



Maroldt.lu

Matériaux de construction - Carrelages - Sanitaires

ouvert: Lu - Fr 8.00 h - 12.00 h et 13.00 h - 18.00 h Sa 8.00 h - 12.30 h

5, rue Kalchesbruck L-1852 Luxembourg
Tel.: 436761 Fax: 436902 maroldt@pt.lu

ORGANISATION

Your competent partners in Luxembourg

QUARTER
HORSE
ASSOCIATION
LUXEMBOURG

Affiliate of the American Quarter Horse Association
Association sans but lucratif Siege social Mompach

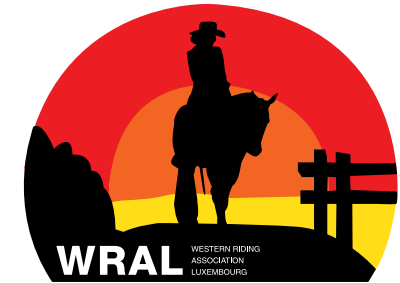

Association sans but lucratif
Siege social Mompach

Affiliate of the FLSE
Affiliate of the NRHA
Affiliate of the NSBA

SHOW-INFORMATION

Show Manager: WRAL/QHAL

Judge: Ricky Bordignon, Italy
Ringsteward: Karin Pauly, Emerange

Show office: tel. 00352 691 729653

Doorman: Patrick Pauly, Luca Frenguellotti
und Jean-Marc Tapiero

Parcourchef: Jean-Marc Tapiero

Vet: Beate Schoof tel. 621 651616

Emergency: 112

Blacksmith: information available at the show office



TEAM WMB

Image nach Maß



KOLLEKTION 2014

Europa Allee 12 · 54343 Föhren

Tel. +49 (0) 65 02 / 99 65 72

Fax +49 (0) 65 02 / 99 69 430

www.team-wmb.de · info@team-wmb.de

Promotion
Arbeitskleidung
Businesskleidung
Stickerei und Druck

TIME SHEET Noertzange (Luxbg.), September 20-21, 2014

Saturday September 20, 2014 show start at 8:00hour

1 JAQHA	1440 HUNTER UNDER SADDLE	OPEN
2 JAQHA	2440 HUNTER UNDER SADDLE	AMATEUR
3 JAQHA	4440 HUNTER UNDER SADDLE	YOUTH
4 JAQHA	3440 HUNTER UNDER SADDLE	Novice/Amat
5 JAQHA	4520 HUNT SEAT EQUITATION	YOUTH
6 JAQHA	2520 HUNT SEAT EQUITATION	AMATEUR
7 JAQHA	1347 GREEN REINING	OPEN
8 NRHA	5310 Reining \$50 ADDED	PATTERN 6
9 WRAL	3812 TRAIL WALK-TROT	ROOKIE L2
10 JAQHA	1383 GREEN TRAIL	BEGINNER
11 WRAL	3802 TRAIL	OPEN
12 WRAL	3801 TRAIL	BEGINNER
13 JAQHA	3380 TRAIL	Novice/Amat
14 JAQHA	5380 TRAIL	Novice Youth
15 WRAL/FLSE	3804 TRAIL	YOUTH
16 WRAL/FLSE	380 TRAIL	OPEN
17 WRAL	4214 WESTERN PLEASURE WALK-TROT	YOUTH
18 WRAL/FLSE	4204 WESTERN PLEASURE	YOUTH
19 WRAL/FLSE	420 WESTERN PLEASURE AA	OPEN
20 WRAL/FLSE	340 REINING	OPEN
21 WRAL/FLSE	3404 REINING	YOUTH
22 WRAL	3402 REINING	BEGINNER
23 NRHA	3100 Reining 25\$ ADDED	PATTERN 6
24 NRHA	3200 Reining 25\$ ADDED	YOUTH 13 U.
25 WRAL	4202 WESTERN PLEASURE	YOUTH 14-18
26 JAQHA	1424 GREEN WESTERN PLEASURE	BEGINNER
27 JAQHA	3420 WESTERN PLEASURE	OPEN
28 JAQHA	5420 WESTERN PLEASURE	Novice/Amat
29 WRAL	4203 RANCH PLEASURE	Novice Youth
30 WRAL	4302 RANCH PLEASURE	OPEN
31 JAQHA	3430 RANCH PLEASURE	BEGINNER
32 JAQHA	4430 RANCH PLEASURE	Novice/Amateur
33 JAQHA	2430 RANCH PLEASURE	YOUTH
34 JAQHA	1360 WESTERN RIDING	AMATEUR
35 JAQHA	2360 WESTERN RIDING	OPEN
36 JAQHA	5340 REINING	Novice Youth
37 JAQHA	2340 REINING	AMATEUR
38 NRHA	1100 150\$ ADDED	PATTERN 10
39 NRHA	1600 100\$ ADDED	PATTERN 10
40 WRAL	2405 HORSEMANSHIP WALK-TROT	BEGINNER
41 WRAL	2401 WESTERN HORSEMANSHIP	AMATEUR
42 JAQHA	4400 WESTERN HORSEMANSHIP	YOUTH
43 WRAL	2402 WESTERN HORSEMANSHIP	BEGINNER
44 JAQHA	2400 WESTERN HORSEMANSHIP	AMATEUR
45 WRAL	240 WESTERN HORSEMANSHIP	OPEN
46 WRAL	349 Freestyle Reining	OPEN

Sunday September 21, 2014 show start at 8:00hour

47 JAQHA	10311 YEARLING STALLIONS	OPEN
48 JAQHA	1032 TWO YEAR OLD STALLIONS	OPEN
49 JAQHA	1033 THREE YEAR OLD STALLIONS	OPEN
50 JAQHA	1034 AGED STALLIONS	OPEN
51 JAQHA	1730 PERFORMANCE STALLIONS	OPEN
52 JAQHA	1054 YEARLING MARES	OPEN
53 JAQHA	1055 TWO YEAR OLD MARES	OPEN
54 JAQHA	1056 THREE YEAR OLD MARES	OPEN
55 JAQHA	1057 AGED MARES	OPEN
56 JAQHA	1750 PERFORMANCE MARES	OPEN
57 JAQHA	1074 YEARLING GELDINGS	OPEN
58 JAQHA	1075 TWO YEAR OLD GELDINGS	OPEN
59 JAQHA	1076 THREE YEAR OLD GELDINGS	OPEN
60 JAQHA	1077 AGED GELDINGS	OPEN
61 JAQHA	1770 PERFORMANCE GELDINGS	OPEN
62 WRAL	1202 SHOWMANSHIP AT HALTER	BEGINNER
63 WRAL	1201 SHOWMANSHIP AT HALTER	AMATEUR
64 JAQHA	2120 SHOWMANSHIP AT HALTER	AMATEUR
65 JAQHA	4120 SHOWMANSHIP AT HALTER	YOUTH
66 JAQHA	3120 SHOWMANSHIP AT HALTER	Novice/Amat
67 JAQHA	5120 SHOWMANSHIP AT HALTER	Novice Youth
68 WRAL	3823 Trail in Hand (all ages)	OPEN
69 JAQHA	2380 TRAIL	AMATEUR
70 JAQHA	4380 TRAIL	YOUTH
71 JAQHA	1380 TRAIL	OPEN
72 WRAL	3823 Horse&Dog Trail	OPEN
73 WRAL	111 LEAD-LINE 10&under	YOUTH
74 WRAL	3401 REINING	AMATEUR
75 JAQHA	4340 REINING	YOUTH
76 JAQHA	3340 REINING	Novice/Amat
77 WRAL	4205 WESTERN PLEASURE WALK-TROT	BEGINNER
78 WRAL	4201 WESTERN PLEASURE	AMATEUR
79 JAQHA	4420 WESTERN PLEASURE	YOUTH
80 JAQHA	1420 WESTERN PLEASURE	OPEN
81 JAQHA	2420 WESTERN PLEASURE	AMATEUR
82 JAQHA	3400 WESTERN HORSEMANSHIP	Novice/Amat
83 JAQHA	5400 WESTERN HORSEMANSHIP	Novice Youth
84 JAQHA	1430 RANCH PLEASURE	OPEN
85 WRAL	4301 RANCH PLEASURE	AMATEUR
86 JAQHA	1340 REINING	OPEN
87 NRHA	1400 Reining 125\$ ADDED	PATTERN 9
88 NRHA	1301 Reining 75\$ ADDED	PATTERN 9
		LTD NON-PRO



www.gama.lu

PEINTURE - DECOR
BERTHAUT & BIVER



TEL. 26 37 09 37
 FAX. 26 37 80 55

info@berthaut-biver.lu

- DÉCORS
- FAÇADES
- REVÊTEMENT DE SOL
- PEINTURE INTÉRIEUR
ET EXTÉRIEUR

5	AQHA	4520	HUNT SEAT EQUITATION	YOUTH
6	AQHA	2520	HUNT SEAT EQUITATION	AMATEUR

AQHA HUNT SEAT EQUITATION (YOUTH AMATEUR)

Show Date: 20 - 21 September 2014

Be ready with your horse's tail to A.

1. Walk two horse lengths from A.
2. Canter on the right lead in a half circle to B.
3. Rising trot on the left diagonal until even with A.
4. Turn left and change diagonals.
5. Rising trot on the right diagonal straight away from A.

Pattern is over once you have passed C at the trot.

Follow the directions of your ring steward.

Walk -----

Trot - - - - -

Extended Trot - - - - -

Canter - - - - -

Lead Change

Back

Marker

Hand Gallop

[HSE/1-46]

Pattern Provided by:
RICKY BORDIGNON

www.HorseShowPatterns.com



CONSTRUCTIONS | FAÇADES | GENIE CIVIL

EIFEL
PferdeZAHNFEE

Equine Dentist Sabine Pauly
 Pferde Zahnbehandlungen
 Telefon: 0171-8092541 • Deudesfeld
 www.eifel-pferdezahnfee.de

30	WRAL	4302	RANCH PLEASURE	BEGINNER
31	AQHA	3430	RANCH PLEASURE	NOVICE AMATEUR
32	AQHA	4430	RANCH PLEASURE	YOUTH
33	AQHA	2430	RANCH PLEASURE	AMATEUR
85	WRAL	4301	RANCH PLEASURE	AMATEUR

WRAL RANCH PLEASURE (BEGINNER - N. AMATEUR - YOUTH - AMATEUR)

Show Date: 20 - 21 September 2014

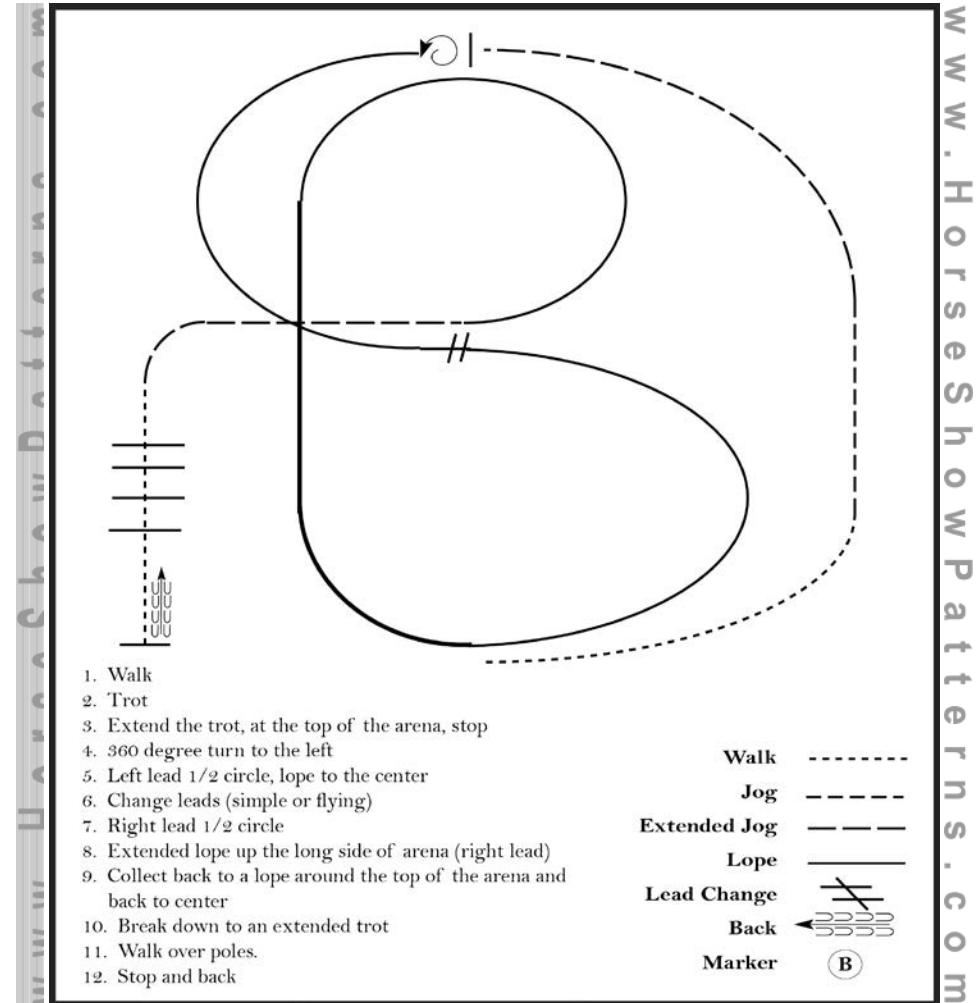

Pattern Provided by:

RICKY BORDIGNON

29	WRAL	4209	RANCH PLEASURE	OPEN
84	AQHA	1430	RANCH PLEASURE	OPEN

AQHA WRAL RANCH PLEASURE (OPEN)

Show Date: 20 - 21 September 2014

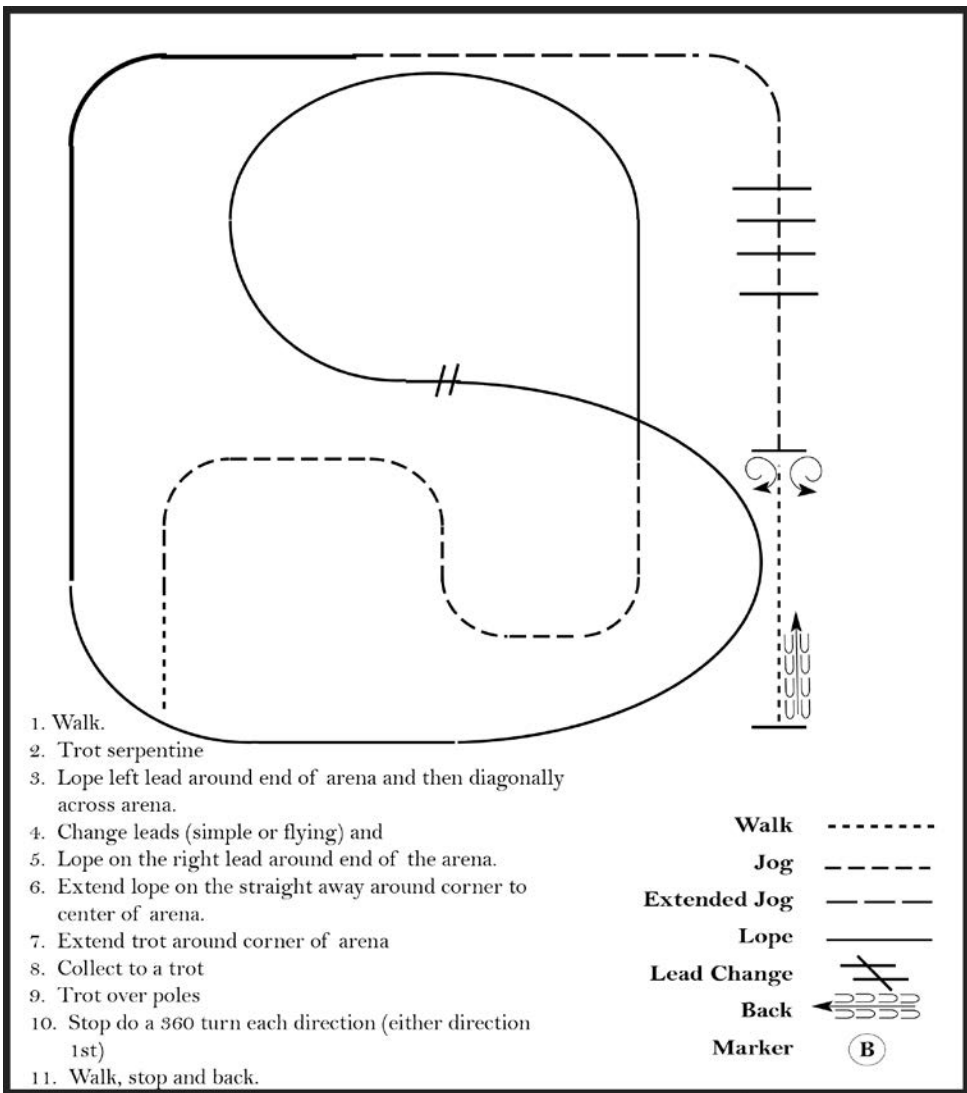

1. Walk.
2. Trot serpentine
3. Lope left lead around end of arena and then diagonally across arena.
4. Change leads (simple or flying) and
5. Lope on the right lead around end of the arena.
6. Extend lope on the straight away around corner to center of arena.
7. Extend trot around corner of arena
8. Collect to a trot
9. Trot over poles
10. Stop do a 360 turn each direction (either direction 1st)
11. Walk, stop and back.

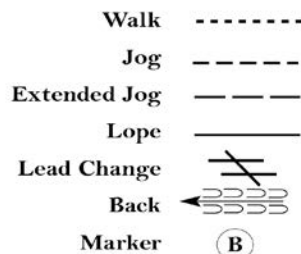

[RP/4]

Pattern Provided by:

RICKY BORDIGNON

43	WRAL	2402	WESTERN HORSEMANSHIP	BEGINNER
82	AQHA	3400	WESTERN HORSEMANSHIP	NOVICE AMAT
83	AQHA	5400	WESTERN HORSEMANSHIP	Novice Youth

AQHA WRAL W. HORSEMANSHIP (BEGINNER / N. AMATEUR / N. YOUTH)

Show Date: 20 - 21 September 2014

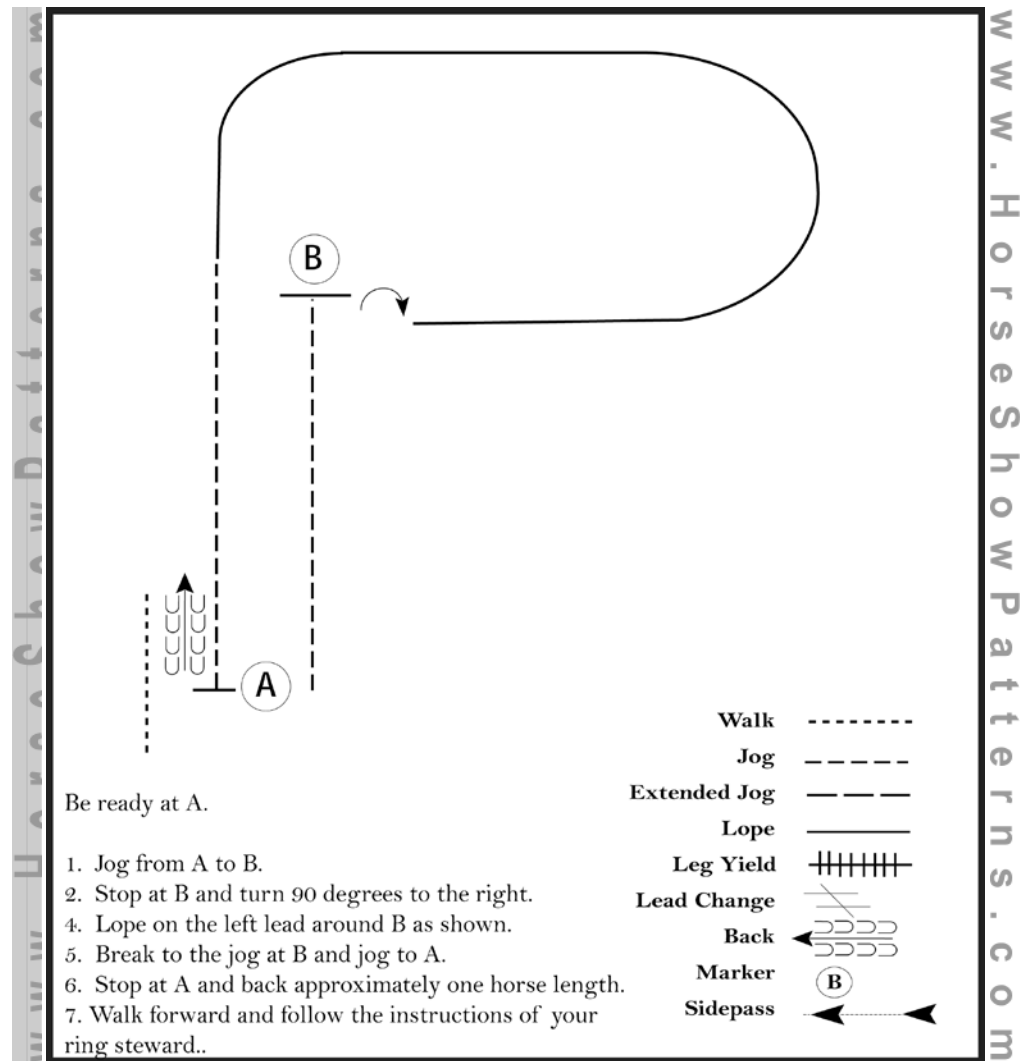

Be ready at A.

1. Jog from A to B.
2. Stop at B and turn 90 degrees to the right.
4. Lope on the left lead around B as shown.
5. Break to the jog at B and jog to A.
6. Stop at A and back approximately one horse length.
7. Walk forward and follow the instructions of your ring steward..

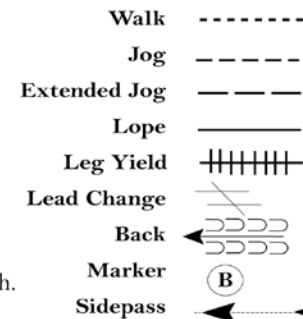

[WH/1-53]

Pattern Provided by:

RICKY BORDIGNON

41	WRAL	2401	WESTERN HORSEMANSHIP	AMATEUR
42	AQHA	4400	WESTERN HORSEMANSHIP	YOUTH
44	AQHA	2400	WESTERN HORSEMANSHIP	AMATEUR



Trierweiler
ENTREPRISE DE CARRELAGE

Carrelages et Pierres naturelles
Vente – Pose
Rénovations
Chapes

Zone commerciale „Um Mierscherbierg“
7, allée J.W.Léonard L-7526 MERSCH

tél: 326095 – expo: 326070 – fax: 327429

www.trierweiler.lu -- info@trierweiler.lu

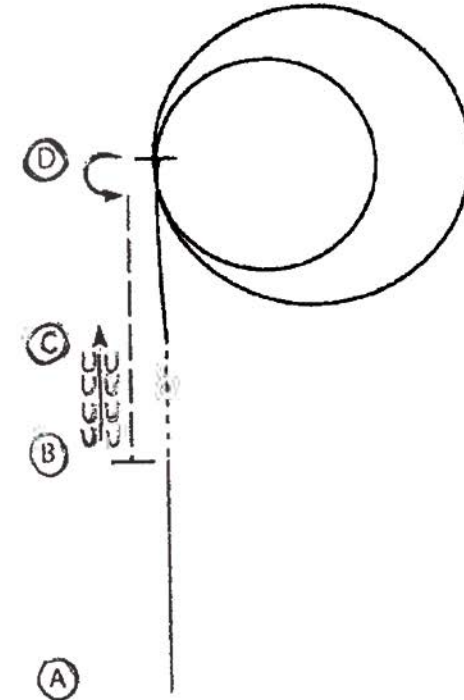

Be ready at A.

1. Lope on the left lead to B.
2. Walk B to C.
3. Lope on the right lead to D.
4. Lope a large fast circle to the right.
5. Lope a small slow circle to the right.
6. Stop at D and perform a 180 degree spin to the left.
7. Extend the jog to B.
8. Stop at B and back to C.

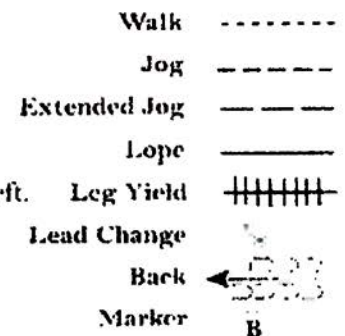

Follow the instructions of your ring steward.

Garage Roby Cruciani

73, route de Luxembourg
L-3515 Dudelange
Tél.: 52 02 52-1 Fax: 52 02 42



Das Auto.

www.carrelagescuri.lu

carrelages
louïs scuri

511726 218 Z. I. Scheleck II BETTEMBOURG

WRAL W. HORSEMANSHIP (OPEN)

Show Date: 20 - 21 September 2014

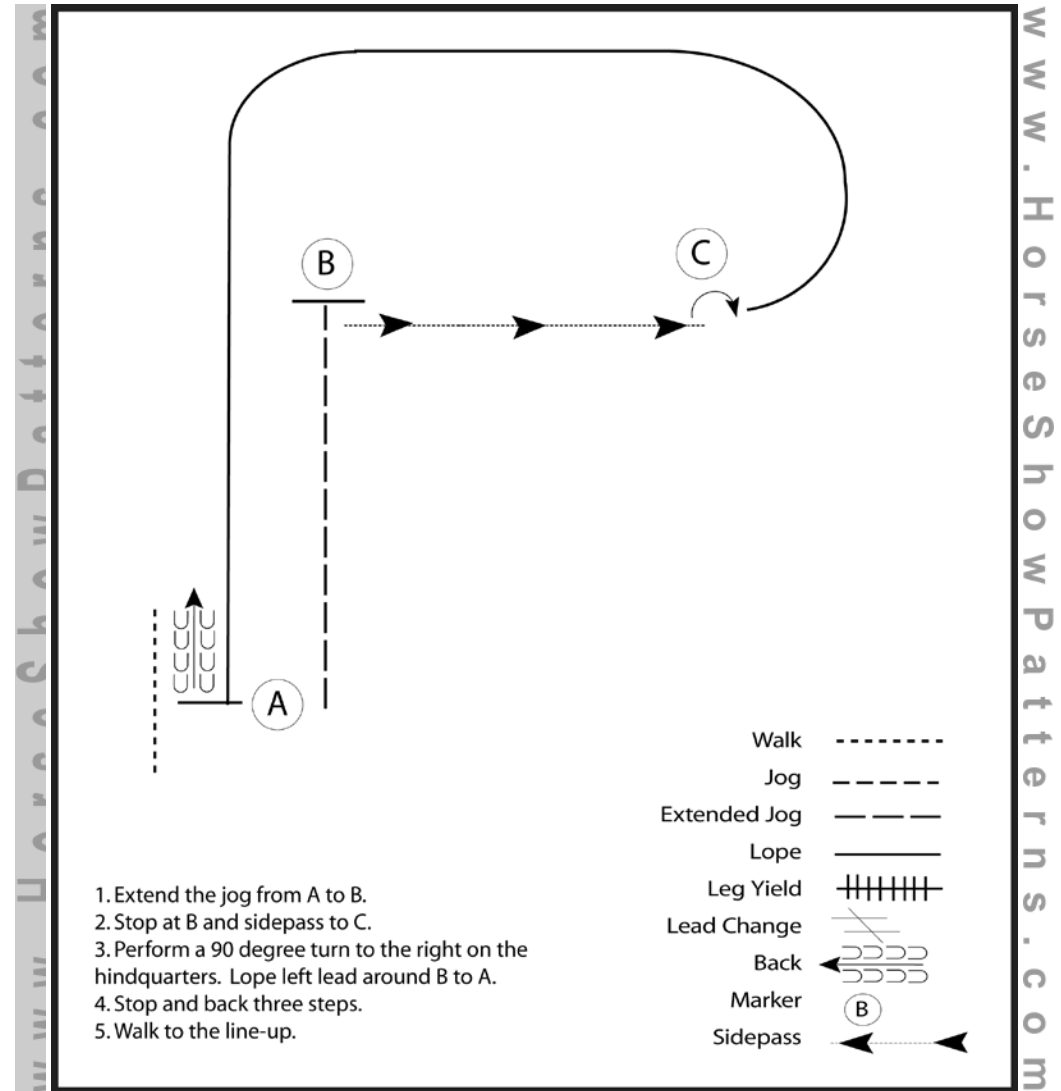

Pattern Provided by:

RICKY BORDIGNON

REIFEN KIEFER



DIE Sicherheitsexperten.

Wir bieten mehr als Reifen!

- Inspektion
- HU / AU-Service
- Autoglas-Service
- Öl-Service
- Bremsen
- Stoßdämpfer
- Klima-Service
- Auspuff
- Batterien
- Elektronische Fahrwerksvermessung
- Reifenfüllgas
- Pflegemittel



Hotline 0180-1000777
 (0,039 €/Min. aus dem Festnetz – Mobilfunk abweichend, max. 0,42 €/Min.)

www.reifen-kiefer.de

In den mit * gekennzeichneten Filialen finden Sie unseren Bosch Car Service

Homburg | Lebach | Orscholz* | Pirmasens | Rehlingen | Saarbrücken | Saarlouis* | Trier*

40 WRAL 2405 HORSEMANSHIP WALK-TROT BEGINNER

AQHA WRAL HORSEMANSHIP W&T (BEGINNER)

Show Date: 20 - 21 September 2014

Be ready at A.

1. Walk approximately 2 horse lengths from A.
2. Jog to B.
3. Turn 1/4 turn to the right.
4. Jog in a half circle to C.
5. Stop at C and back approximately one horse length.

Follow the instructions of your ring steward.

Walk - - - - -
 Jog - - - - -
 Extended Jog - - - - -
 Lope - - - - -
 Leg Yield |||||
 Lead Change / \ / \ / \ / \
 Back ← ○ ○ ○ ○ ○
 Marker ○ B
 Sidepass - - - - - ← ←

www.HorseShowPatterns.com

Pattern Provided by:
RICKY BORDIGNON



Vanessa Weiler
www.equi-aktiv.de
 Tel. 0170 - 477 51 54

63	WRAL	1201	SHOWMANSHIP AT HALTER	AMATEUR
64	AQHA	2120	SHOWMANSHIP AT HALTER	AMATEUR
65	AQHA	4120	SHOWMANSHIP AT HALTER	YOUTH

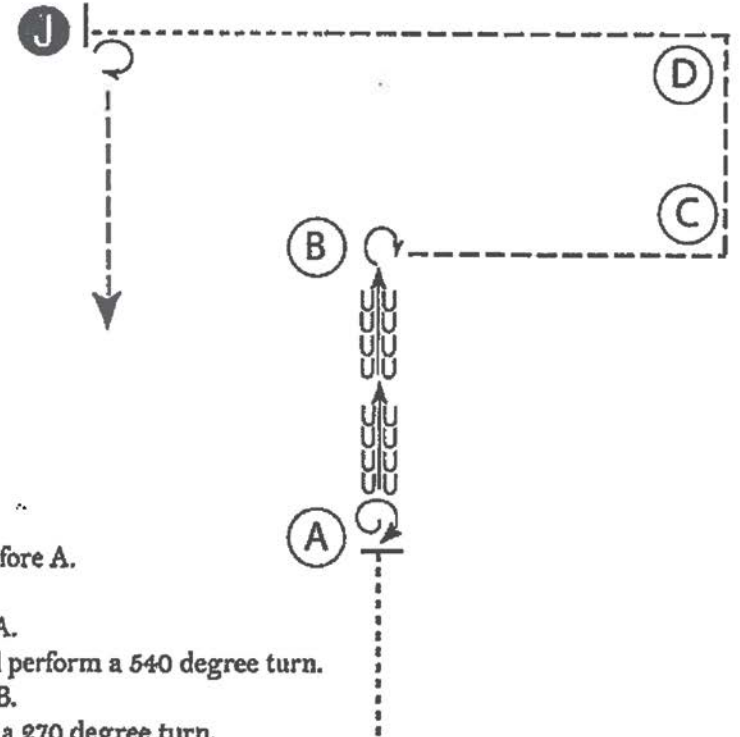

Be ready before A.

1. Walk to A.
2. Stop and perform a 270 degree turn.
3. Back to B.
4. Perform a 270 degree turn.
5. Trot square corners around C and D toward judge.
6. When even with B, break to a walk.
7. Walk to judge.
8. Stop and set up for inspection.
9. When dismissed, perform a 270 degree turn and trot straight away from judge.

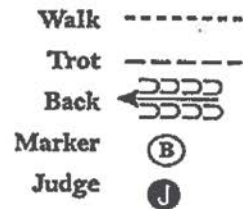

Follow the instructions of your ring steward.



Dawen-Weibler

Weingut · Gästezimmer · Straußwirtschaft

Waldrach · Thommer Straße 1

www.dawen-weibler.eu

De la chaleur pour tous.



Tout le monde peut sauver la planète.



De l'inspiration pour tous.



Tout le monde peut trouver sa propre ambiance de salle de bains.



Un budget pour tous.



Des solutions pour tous.



Eau et chaleur pour tous.

Dans votre magasin Van Marcke Inspirations, vous trouverez la salle de bains, wellness ou installation de chauffage qui vous conviendra le mieux et surtout dans votre budget. Nos conseillers sont fins prêts pour trouver avec vous les meilleures solutions que vous recherchez. En venant, assurez-vous de prendre avec vous tous vos rêves de salle de bains, de wellness ou de chauffage!

Van Marcke Inspirations - 34/38 Rangwee - 2412 Luxembourg
Heures d'ouverture: mardi - samedi 10h00 - 18h00 (fermé le dimanche et lundi)

www.vanmarcke.com



62	WRAL	1202	SHOWMANSHIP AT HALTER	BEGINNER
66	AQHA	3120	SHOWMANSHIP AT HALTER	Novice Amat
67	AQHA	5120	SHOWMANSHIP AT HALTER	Novice Youth

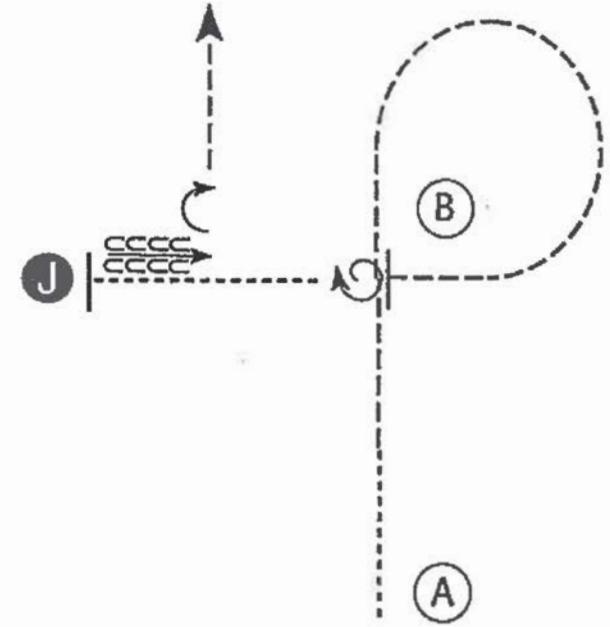

Be ready at A.

1. Walk halfway to B.
2. Trot to and around B as shown.
3. Stop when just past B. Perform a 360 degree turn.
4. Walk to judge and set up for inspection.
5. When dismissed, back one horse length.
6. Perform a 90 degree turn and trot away.

Follow the instructions of your ring steward.

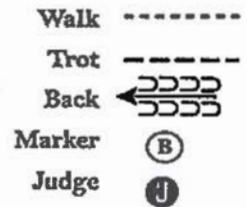

Teamwork zahlt sich aus: Viessmann
Brennwerttechnik mit Solarsystemen.

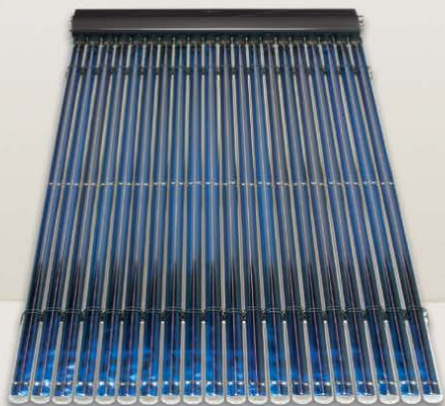

Kostenlose Sonnenenergie
als optimale Ergänzung
zum Gas-Brennwertkessel
Vitodens 300-W:

- Brennwertkessel der Spitzenklasse
- Langlebiger Inox-Radial-Edelstahlwärmetauscher
- Energieeinsparung bis zu 35 % durch solare Warmwasserbereitung und Heizungsunterstützung
- Schont die fossilen Ressourcen

Wir beraten Sie gern:

CHAUFFAGE · SANITAIRE
Baumert

VIESSMANN



CHAUFFAGE · SANITAIRE
Baumert

WWW.BAUMERT-ENT.LU



BGL
BNP PARIBAS

phillipps
S.à.r.l.
Immer eine Idee besser

RAUMVERGNÜGEN.

Das Auge wohnt mit.
Gönnen Sie sich frische,
schöne Aussichten mit
unserem kreativen
Raumprogramm.

Rufen Sie uns an!

Peinture Phillipps Sàrl

7, rue de Godbrange
L-6118 Junglinster
Tel.: 00352 / 42 64 95

3, rue de la Déportation
L-1415 Luxembourg Hollerich
Tel.: 00352 / 42 64 95-40

RAUMPROGRAMM.

- klassische Maler- und Lackiererarbeiten
- hochwertige dekorative Gestaltungstechniken
- Bodenbeläge
- Spanndecken
- Elektroarbeiten
- 100 % Service – bis hin zum Aus-/Einräumen und zur Profi-Bauschlussreinigung

info@phillipps.lu
www.phillipps.lu



AQHA WESTERN RIDING (AMATEUR)

Show Date: 20 - 21 September 2014

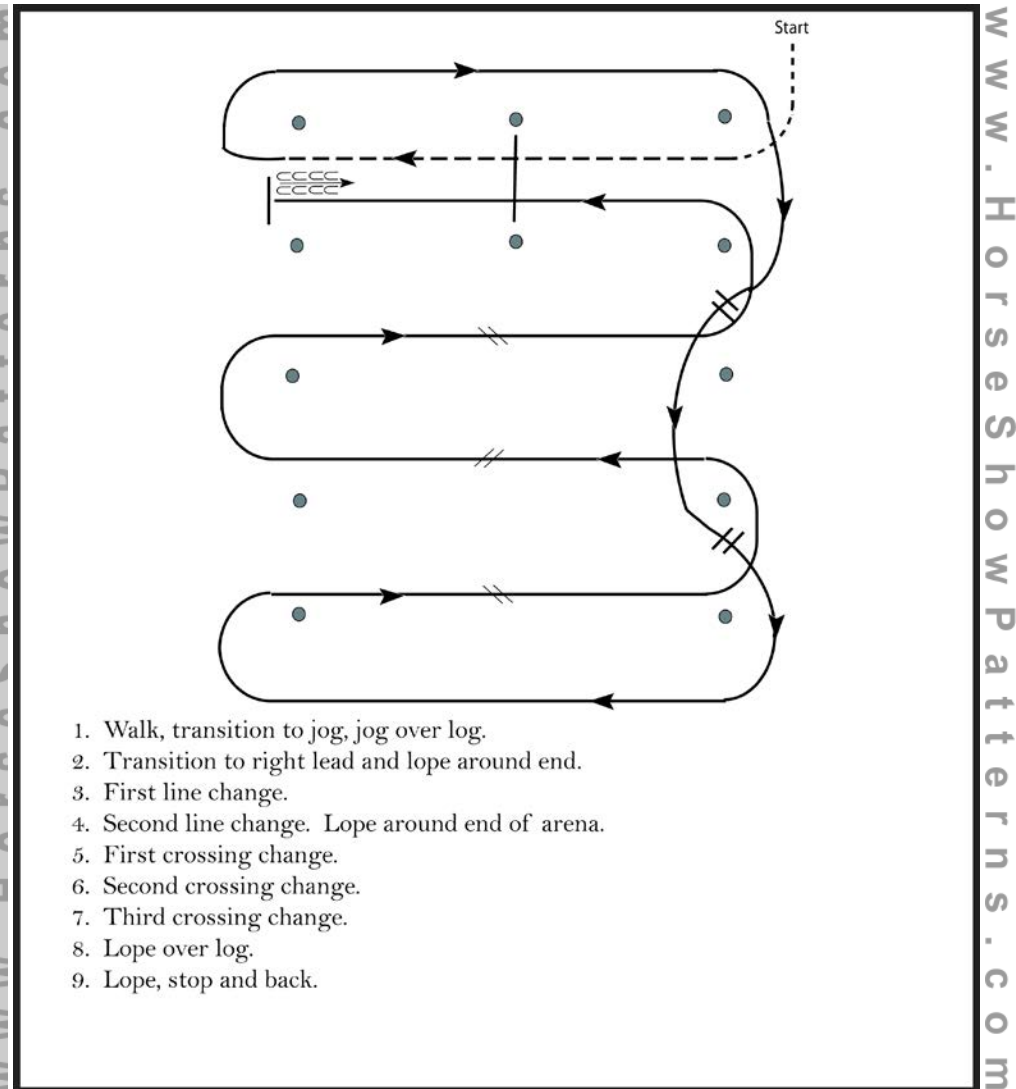

Pattern Provided by:

RICKY BORDIGNON

©2014 HorseShowPatterns.com. All Rights Reserved.

[WR/GP-4]

34	AQHA	1360	WESTERN RIDING	OPEN
----	------	------	----------------	------

8	NRHA	5310	Reining \$50 ADDED PATTERN 6	ROOKIE L2
23	NRHA	3100	Reining 25\$ ADDED PATTERN 6	YOUTH 13 U.
24	NRHA	3200	Reining 25\$ ADDED PATTERN 6	YOUTH 14-18

AQHA WESTERN RIDING (OPEN)

Show Date: 20 - 21 September 2014

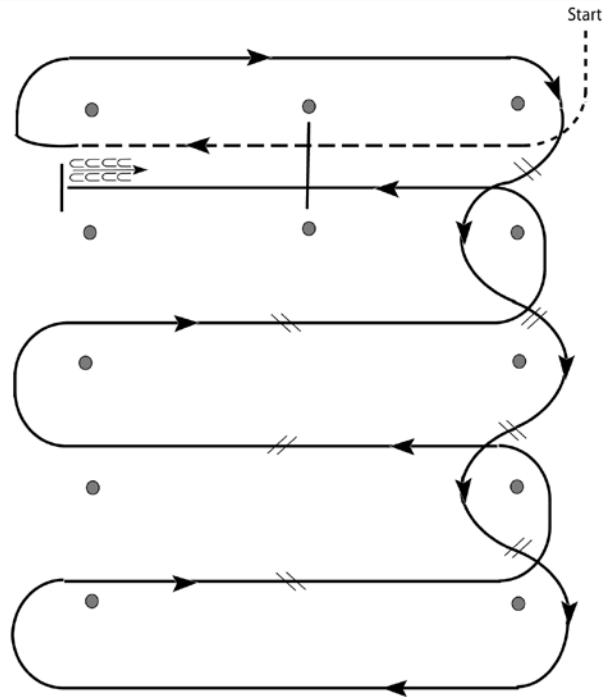

1. Walk, transition to jog, jog over log.
2. Transition to right.
3. First line change.
4. Second line change.
5. Third line change.
6. Fourth line change.
7. First crossing change.
8. Second crossing change.
9. Third crossing change.
10. Lope over log.
11. Lope, stop and back.

[WR/OP-4]

Pattern Provided by:

RICKY BORDIGNON

©2014 HorseShowPatterns.com. All Rights Reserved.

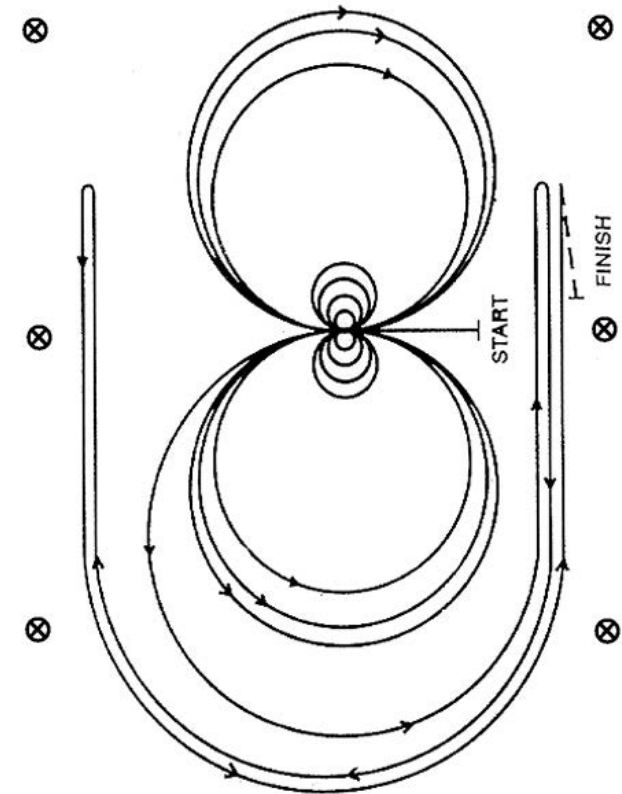

Horse must walk or stop prior to starting pattern.

Beginning at the center of the arena facing the left wall or fence.

1. Complete four spins to the right.
 2. Complete four spins to the left. Hesitate.
 3. Beginning on the left lead, complete three circles to the left: the first two circles large and fast; the third circle small and slow. Change leads at the center of the arena.
 4. Complete three circles to the right: the first two circles large and fast; the third circle small and slow. Change leads at the center of the arena.
 5. Begin a large fast circle to the left but do not close this circle. Run up the right side of the arena past the center marker and do a right rollback at least 20 feet (6 meters) from the wall or fence - no hesitation.
 6. Continue back around previous circle but do not close this circle. Run up the left side of the arena past the center marker and do a left rollback at least 20 feet (6 meters) from the wall or fence - no hesitation.
 7. Continue back around previous circle but do not close this circle. Run up the right side of the arena past the center marker and do a sliding stop at least 20 feet (6 meters) from the wall or fence. Back up at least 10 feet (3 meters). Hesitate to demonstrate the completion of the pattern.
- Rider may drop bridle to the designated judge.



TOM WINTER



Tom Winter Saddlery
Fellener Weg 5
D - 97773 Aura im Sinngrund

Telefon 09356 / 999944
Telefax 09356 / 934905
Mobil 0151 / 588 58 550

www.wintersaddlery.de

20	WRAL/FLSE	340	REINING	OPEN
86	AQHA	1340	REINING	OPEN
87	NRHA	1400	Reining 125\$ ADDED PATTERN 9	NON-PRO
88	NRHA	1301	Reining 75\$ ADDED PATTERN 9	LTD NON-PRO

Show Date: 20 - 21 September 2014

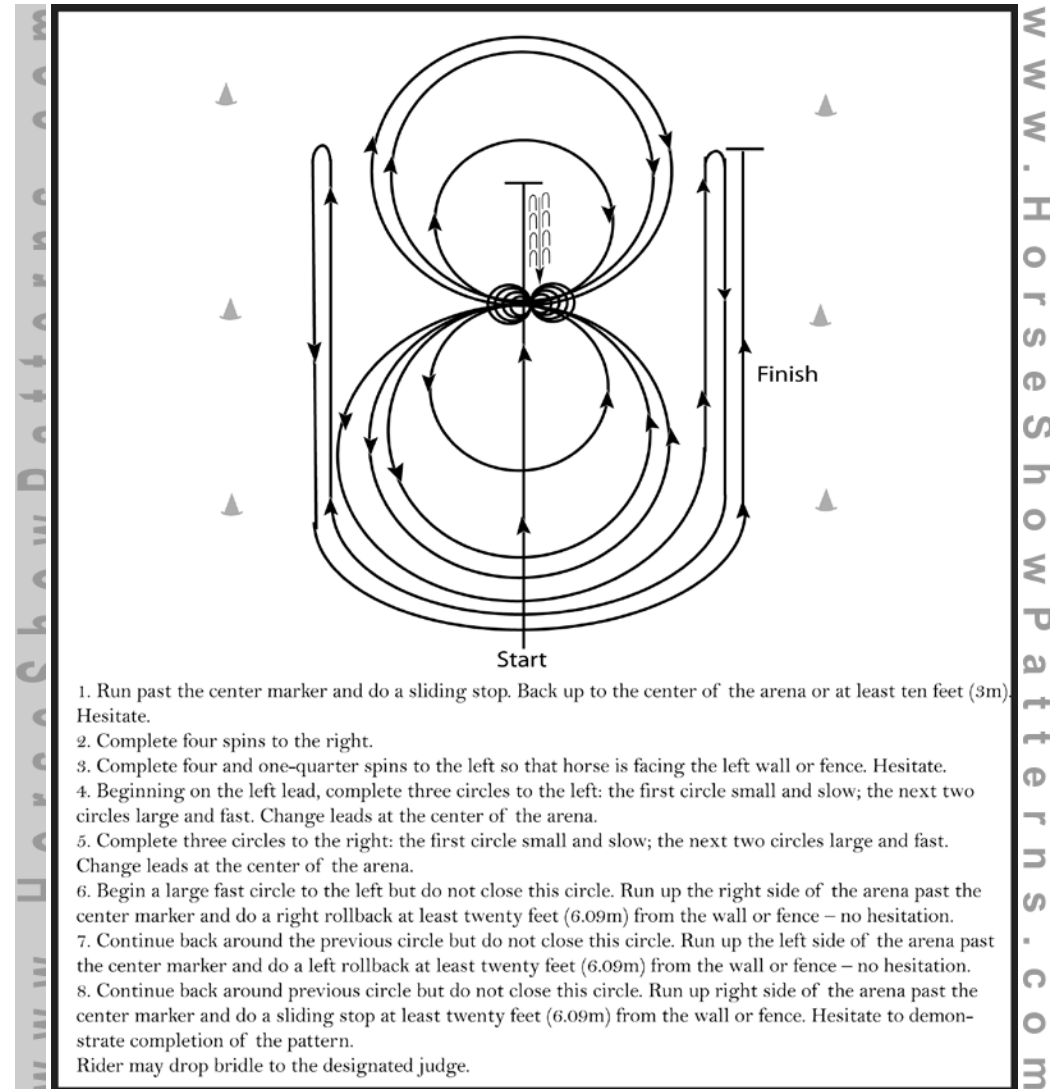

[R/AQHAP-9]

Pattern Provided by:
RICKY BORDIGNON

menuiserie
parachèvement



 26 36 11 61

 26 36 11 62

 621 375 444

 proluxsa@vo.lu

 www.proluxsa.lu

7	AQHA	1347	GREEN REINING	OPEN
22	WRAL	3402	REINING	BEGINNER
36	AQHA	5340	REINING	Novice Youth
76	AQHA	3340	REINING	Novice Amat

Show Date: 20 - 21 September 2014

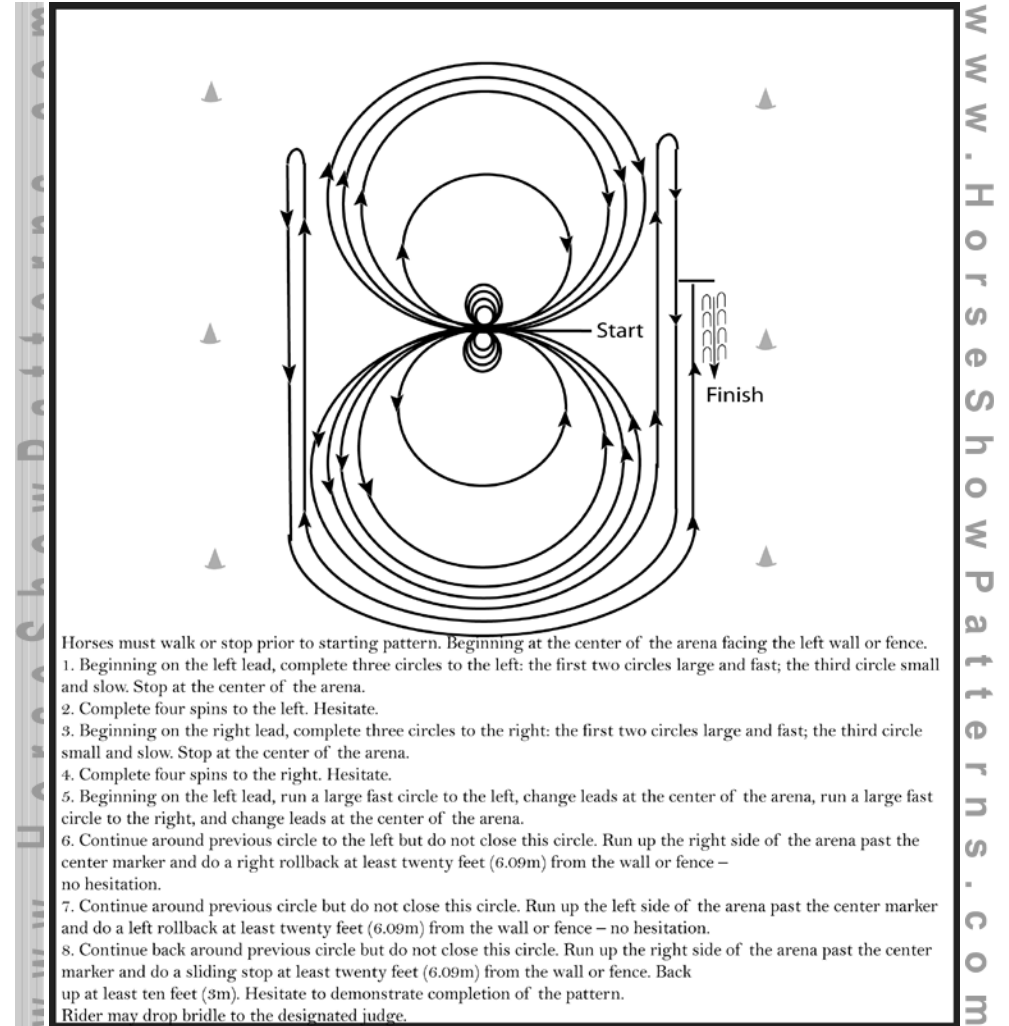

Horses must walk or stop prior to starting pattern. Beginning at the center of the arena facing the left wall or fence.

1. Beginning on the left lead, complete three circles to the left: the first two circles large and fast; the third circle small and slow. Stop at the center of the arena.
2. Complete four spins to the left. Hesitate.
3. Beginning on the right lead, complete three circles to the right: the first two circles large and fast; the third circle small and slow. Stop at the center of the arena.
4. Complete four spins to the right. Hesitate.
5. Beginning on the left lead, run a large fast circle to the left, change leads at the center of the arena, run a large fast circle to the right, and change leads at the center of the arena.
6. Continue around previous circle to the left but do not close this circle. Run up the right side of the arena past the center marker and do a right rollback at least twenty feet (6.09m) from the wall or fence – no hesitation.
7. Continue around previous circle but do not close this circle. Run up the left side of the arena past the center marker and do a left rollback at least twenty feet (6.09m) from the wall or fence – no hesitation.
8. Continue back around previous circle but do not close this circle. Run up the right side of the arena past the center marker and do a sliding stop at least twenty feet (6.09m) from the wall or fence. Back up at least ten feet (3m). Hesitate to demonstrate completion of the pattern.

Rider may drop bridle to the designated judge.

[R/AQHAP-5]

Pattern Provided by:
RICKY BORDIGNON



D.G. Rendiel

Western-Store

Tack & Showoutfits



Sophienstraße 1
 DE 66557 Illingen-Uchtelfangen
 Telefon: +49 (0) 68 25 - 40 41 239
 Mobil: +49 (0) 163 - 24 55 697
 Fax: +49 (0) 68 25 - 40 41 239
 D.G.Rendiel69@gmx.de

www.Rendiel-Westernstore.de ...und hier vor Ort für Sie da!

21	WRAL/FLSE	3404	REINING		YOUTH
37	AQHA	2340	REINING		AMATEUR
74	WRAL	3401	REINING		AMATEUR
75	AQHA	4340	REINING		YOUTH
38	NRHA	1100	150\$ ADDED	PATTERN 10	OPEN
39	NRHA	1600	100\$ ADDED	PATTERN 10	LTD OPEN

Show Date: 20 - 21 September 2014

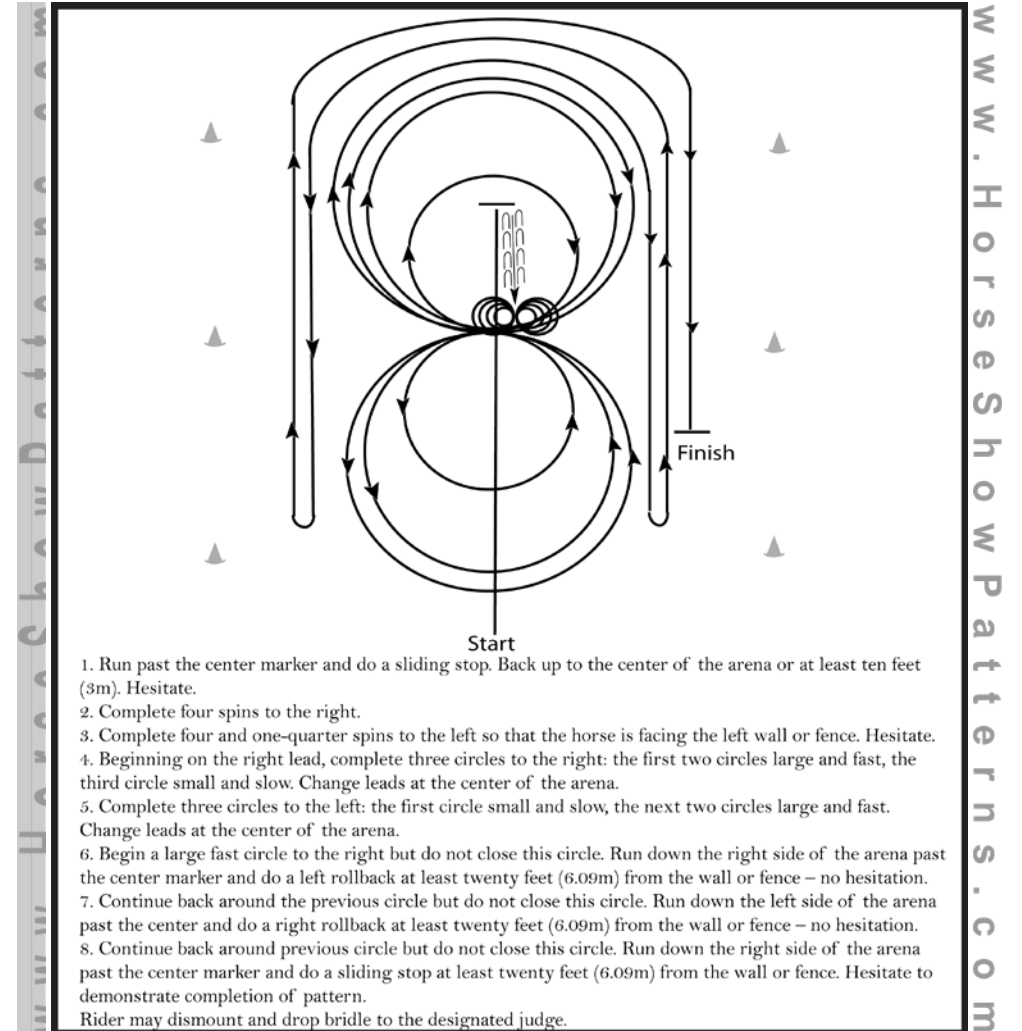

[R/NRhap-10]

Pattern Provided by:
RICKY BORDIGNON

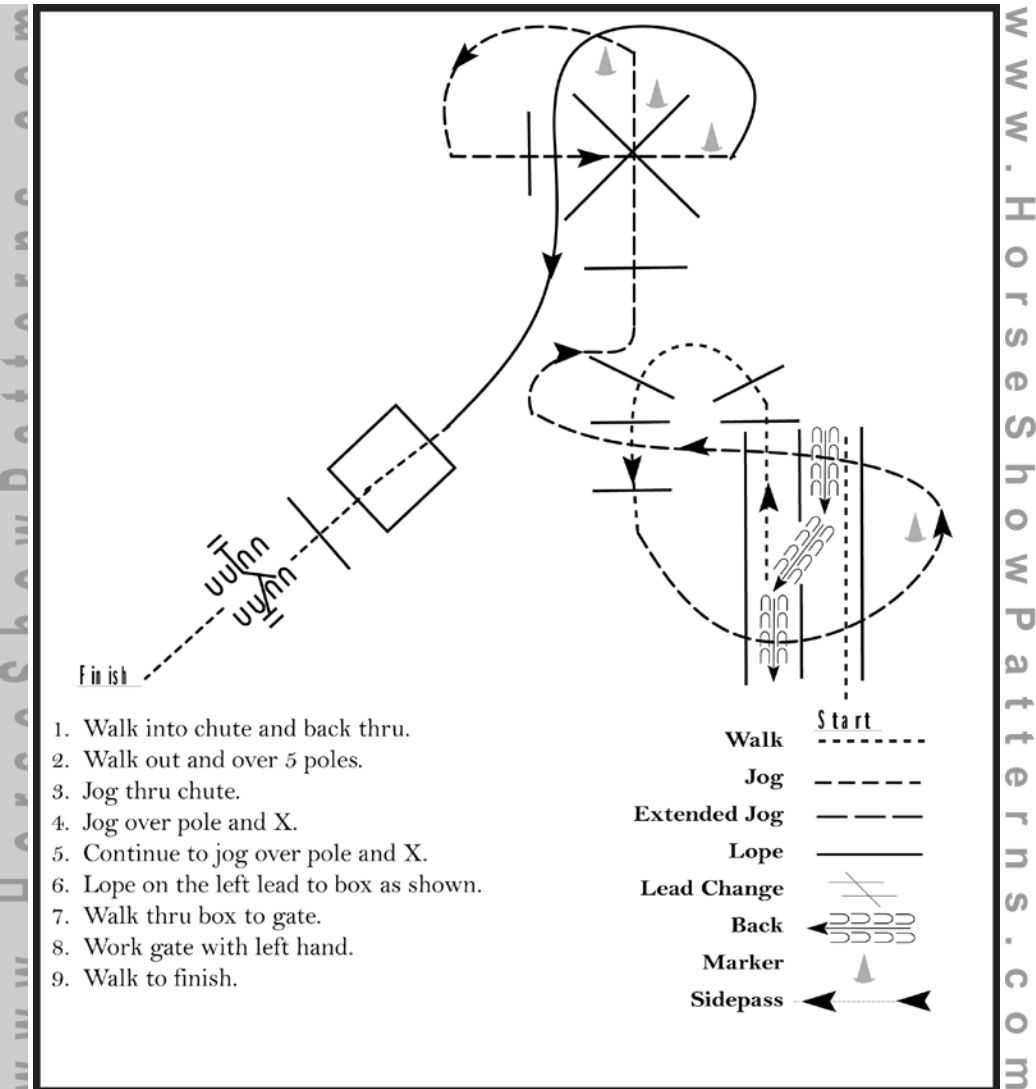
AQHA GREEN TRAIL (OPEN)*Show Date: 20 - 21 September 2014*

1. Walk into chute and back thru.
2. Walk out and over 5 poles.
3. Jog thru chute.
4. Jog over pole and X.
5. Continue to jog over pole and X.
6. Lope on the left lead to box as shown.
7. Walk thru box to gate.
8. Work gate with left hand.
9. Walk to finish.

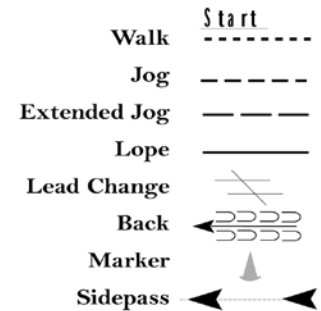

[T/1-35]

Pattern Provided by:**RICKY BORDIGNON**

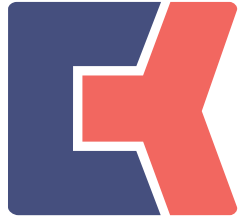

ANC. ETS CLOOS & KRAUS S.À.R.L.
SUCC.: SIEBENALLER ROMAIN & FILS
Machines agricoles, industrielles et espaces verts

ZAC Jauschwis | Tél.: +352 85 92 92 
L-7759 ROOST | www.clooskraus.lu 



11	WRAL	3802	TRAIL	BEGINNER
13	AQHA	3380	TRAIL	Novice Amat
14	AQHA	5380	TRAIL	Novice Youth

AQHA WRAL TRAIL (BEGINNER / N. AMAT / N. YOU)

Show Date: 20 - 21 September 2014

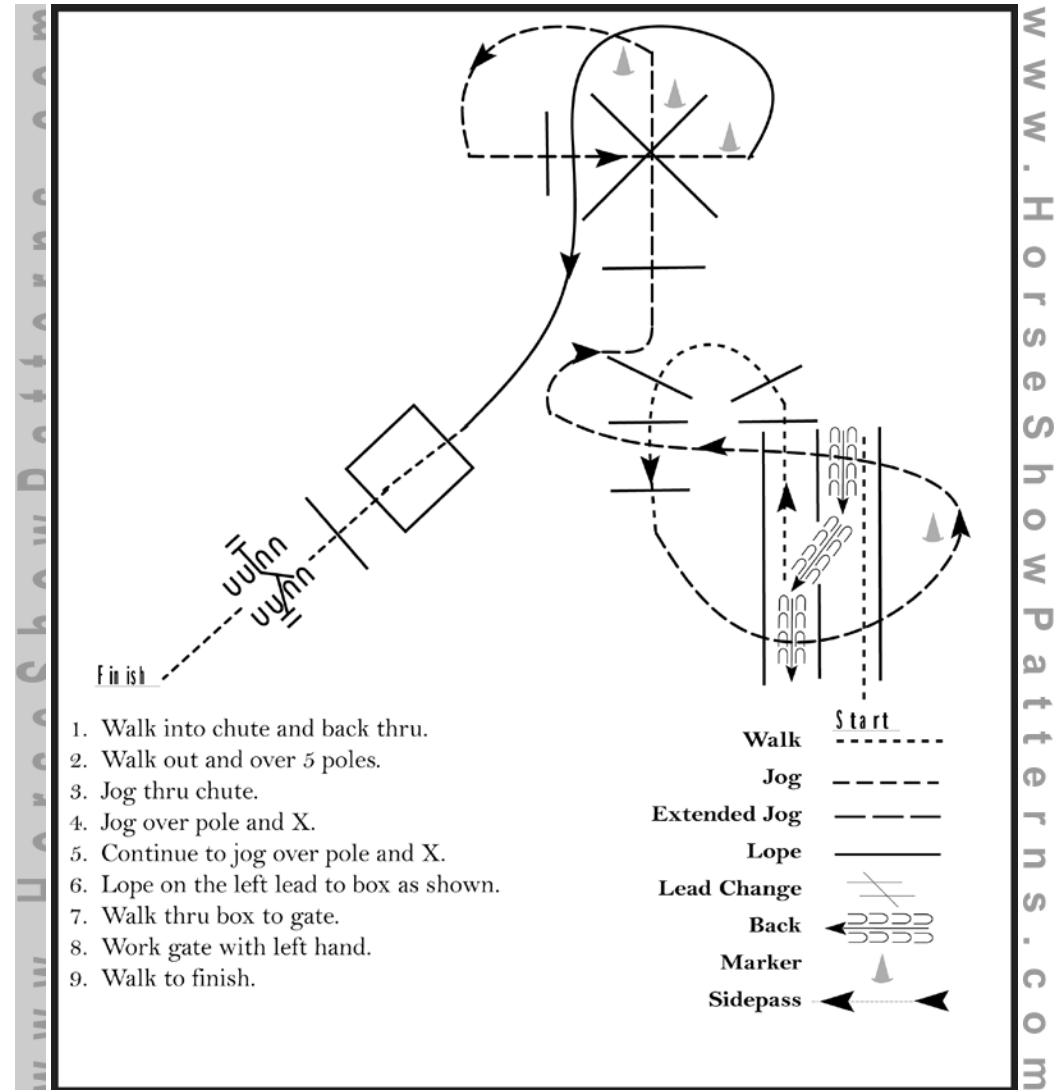

1. Walk into chute and back thru.
2. Walk out and over 5 poles.
3. Jog thru chute.
4. Jog over pole and X.
5. Continue to jog over pole and X.
6. Lope on the left lead to box as shown.
7. Walk thru box to gate.
8. Work gate with left hand.
9. Walk to finish.

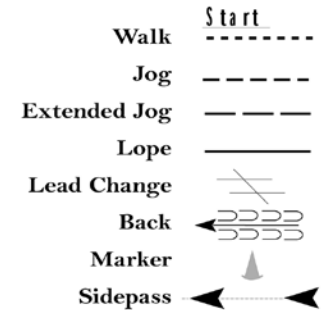

[T/1-35]

Pattern Provided by:
RICKY BORDIGNON

WRAL TRAIL WALK AND TROT (BEGINNER)

Show Date: 20 - 21 September 2014

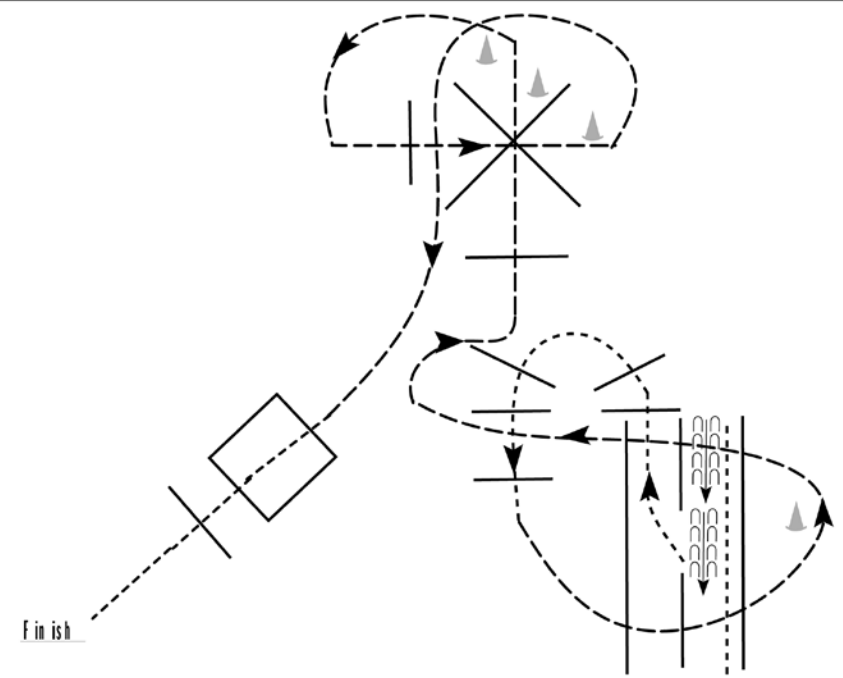

1. Walk into chute and back straight.
2. Walk out and over 5 poles.
3. Jog thru chute.
4. Jog over pole and X.
5. Continue to jog over pole and X.
6. Jog to box as shown.
7. Walk thru box and pole to finish.

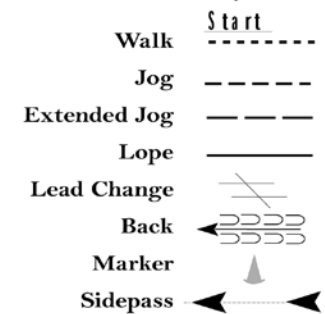

[T/WT-35]

Pattern Provided by:

RICKY BORDIGNON

ICP

MERSCH-WILTZ

GOODYEAR

WWW.ICP.LU

Z.L um Mierscherbiertg
L-7526 Mersch
Tel: 26 32 52 -1

38 A, rue Michel Thilges
L-9573 Wiltz
Tel: 26 95 00 10

Inter Central Pneu

PNEUS, JANTES, REMORQUES, ACCESSOIRES

12	WRAL	3801	TRAIL	AMATEUR
15	WRAL/FLSE	3804	TRAIL	YOUTH
69	AQHA	2380	TRAIL	AMATEUR
70	AQHA	4380	TRAIL	YOUTH

AQHA WRAL TRAIL (AMATEUR / YOUTH)

Show Date: 20 - 21 September 2014

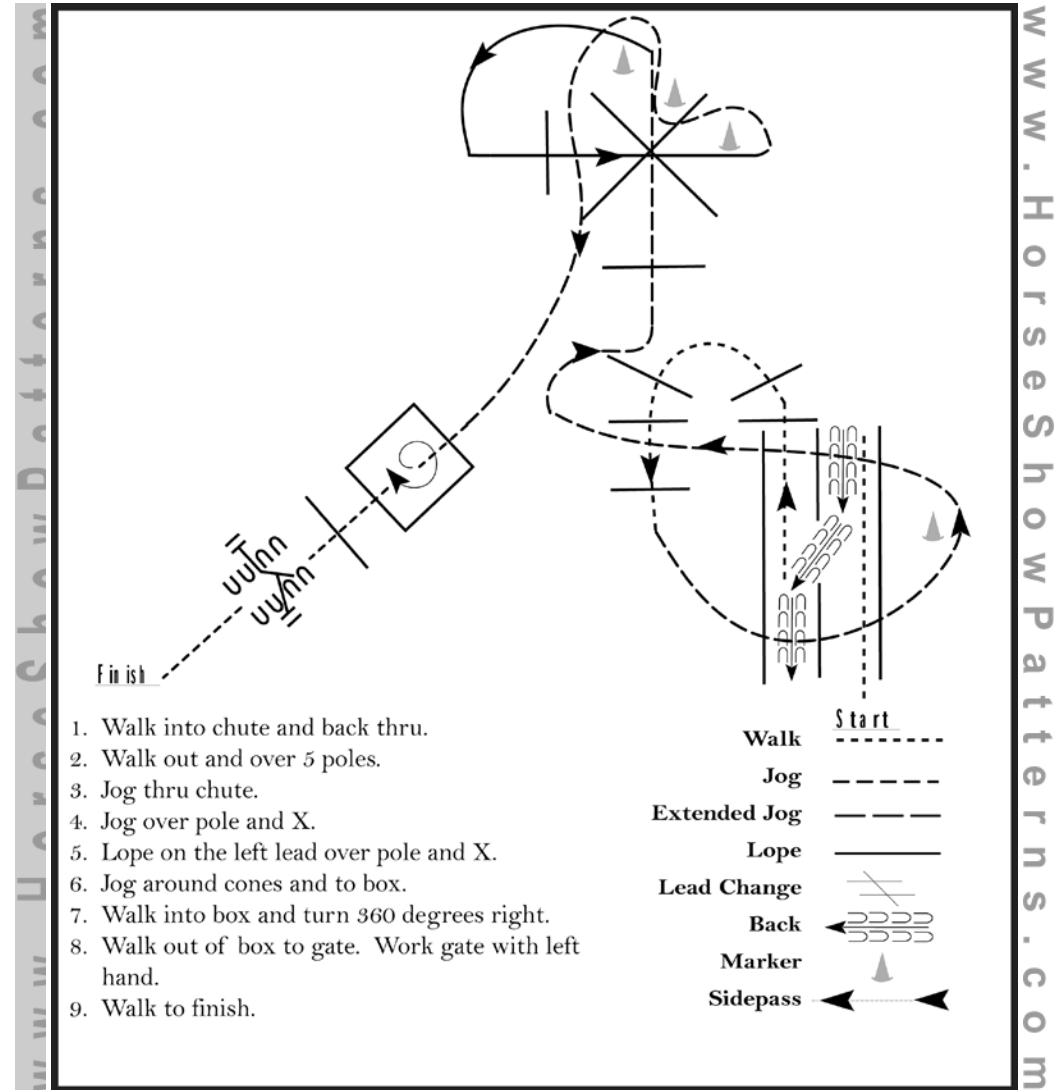

Pattern Provided by:

RICKY BORDIGNON

[T/2-35]

16	WRAL/FLSE	380	TRAIL	OPEN
71	AQHA	1380	TRAIL	OPEN



phillipps
S.à.r.l.
Immer eine Idee besser

FASSADENFEST.

Sie wärmt. Sie zeigt sich von ihrer besten Seite. Sie ist eine wahre Augenweide: Ihre Fassade – aus unseren Händen!

Rufen Sie uns an!

Peinture Phillipps Sàrl

7, rue de Godbrange
L-6118 Junglinster
Tel.: 00352 / 42 64 95

3, rue de la Déportation
L-1415 Luxembourg Hollerich
Tel.: 00352 / 42 64 95-40

FASSADENPROGRAMM.

- Wärmedämm-Verbundsysteme – Planung und Montage
- Fassadenputze
- Fassadensanierung
- Fassadengestaltung

info@phillipps.lu
www.phillipps.lu



AQHA WRAL FLSE TRAIL (OPEN)

Show Date: 20 - 21 September 2014

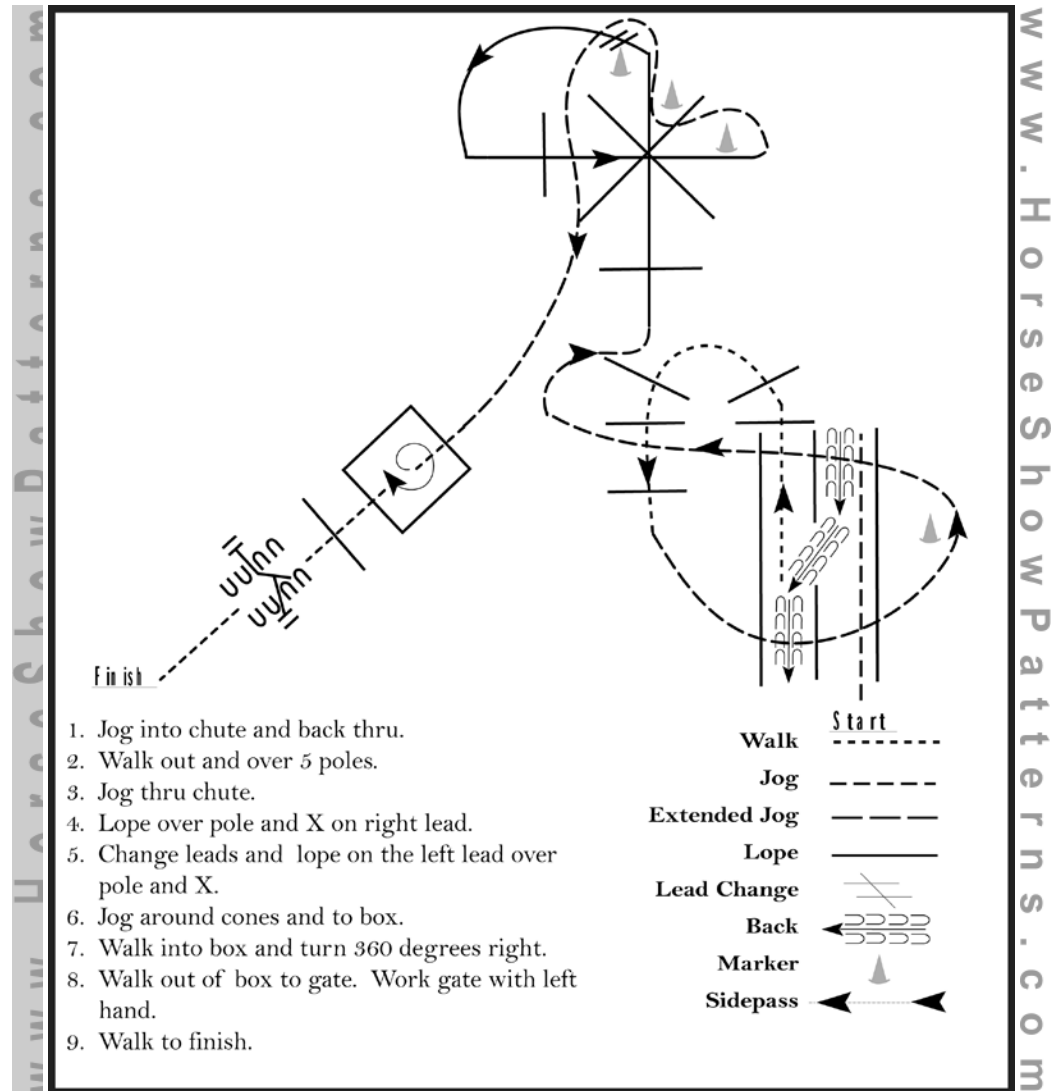

Pattern Provided by:

RICKY BORDIGNON

©2014 HorseShowPatterns.com. All Rights Reserved.

[T/3-35]

WRAL TRAIL IN HAND (ALL AGES)

Show Date: 20 - 21 September 2014

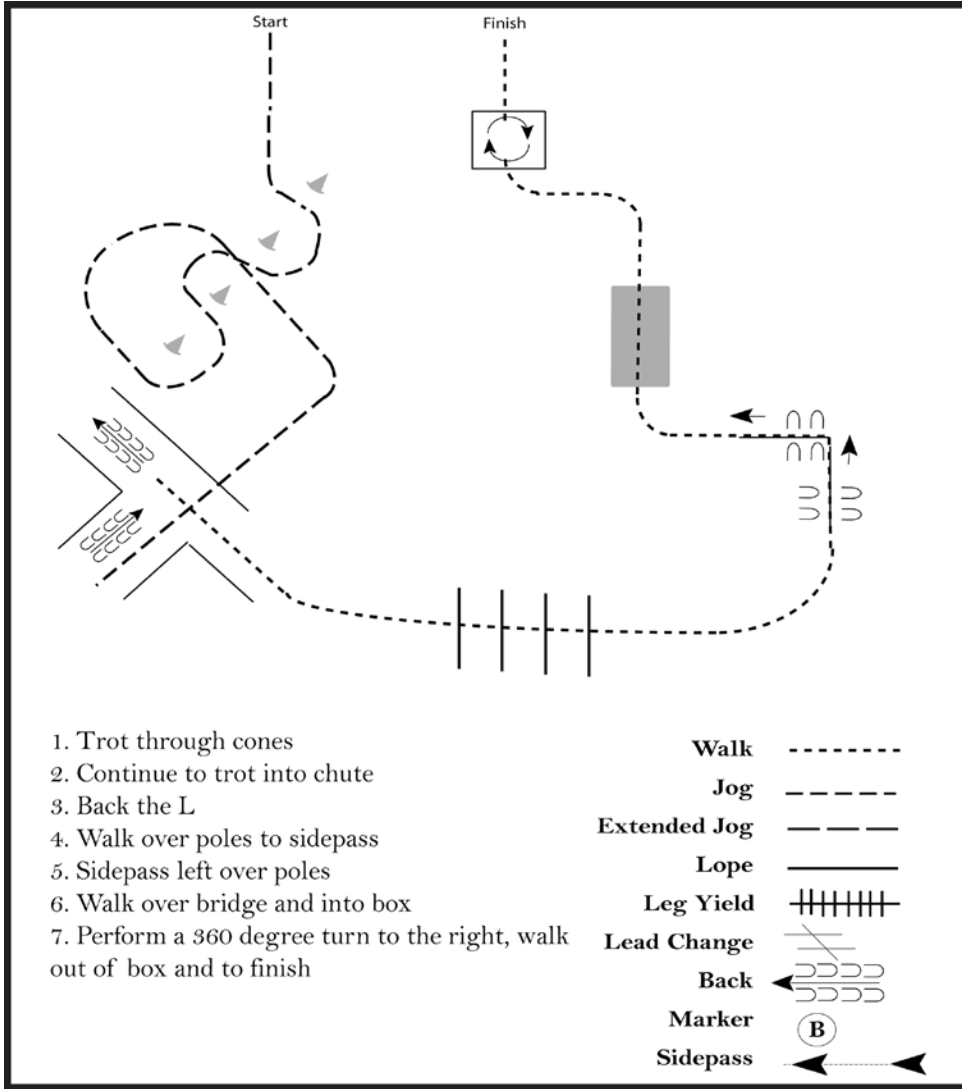

www.HorseShowPatterns.com

[T/1-3]

Pattern Provided by:
RICKY BORDIGNON

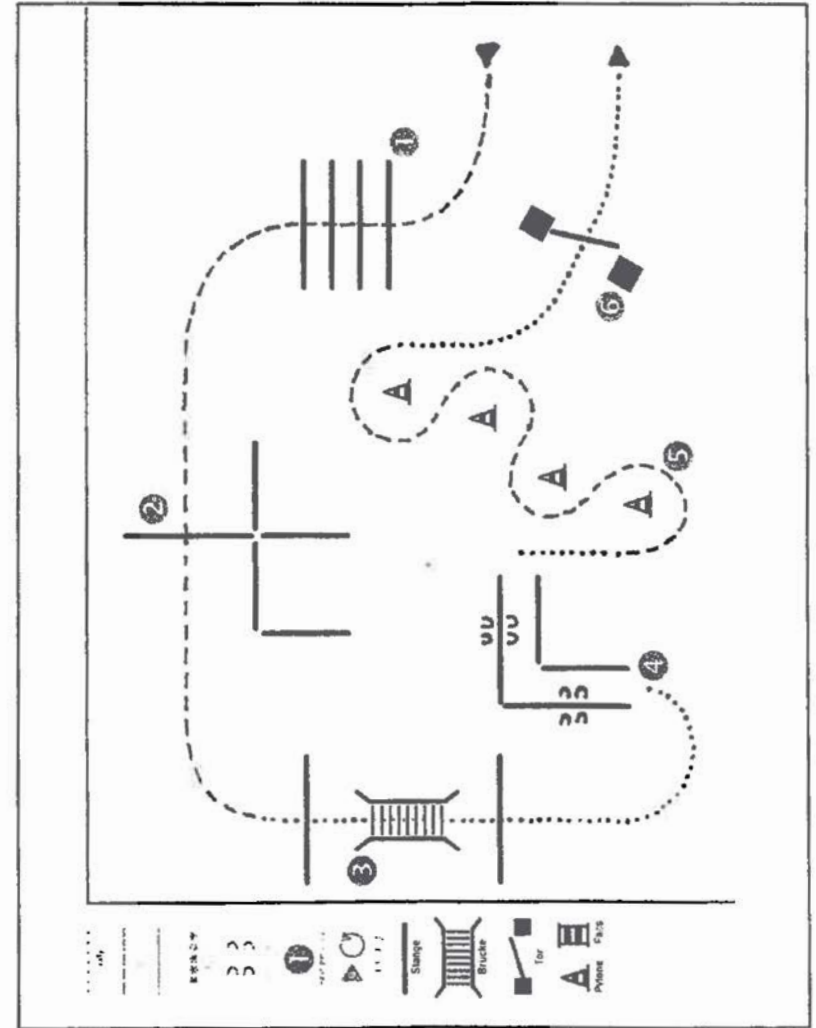

- beim Eintritt in die Arena im Schritt ist der Hund angeleint und läuft bei Fuß (Seite spielt keine Rolle) der Hund wird an der Pylone angeleint
- zu 1.) im Trab über die Stangen, der Hund geht bei Fuß, Trab zu 2.)
- zu 2.) im Trab über die Stange, der Hund geht bei Fuß, Schritt zu 3.)
- zu 3.) im Schritt über die Brücke, der Hund wird geschickt oder hinterhergerufen, Schritt zu 4.)
- zu 4.) der Hund wird abgelegt, der Reiter geht seitwärts über die Stangen, der Hund wird abgerufen, Schritt zu 5.)
- zu 5.) im Trab um die Pylonen, der Hund geht bei Fuß, Schritt zu 6.)
- 6.) der Reiter reitet im Schritt zum Tor und reitet hindurch, der Hund wird abgerufen
- Schritt zum Ausgang, der Hund wird an der Pylone angeleint
- Ende der Prüfung, im Schritt die Arena verlassen

GARAGE COLLÉ S.A.

Concessionnaire officiel
FORD et **VOLVO**

📍 Route de Bascharage
L-4513 **Differdange**
☎ +352 58 48 42 - 1

🌐 www.colle.lu



COLLE



Vente & achat • Service dépannage 24h/7
Station service • Mécanique toutes marques
Carrosserie agréée • Car wash

